

GATE VALVE (FOR FIRE PROTECTION)

Resilient Wedge Gate Valve with Outside Screw & Yoke (OS&Y) and Non-rising Stem (NRS)



TECHNICAL DATA

MODELS:

OS&Y TYPE	GVRS 300 (2" to 12") GVRS-16-300 (2" to 8") GVRS-16-250 (10", 12") GVRS-300-GG (2" to 12") GVRS-16-300-GG (2" to 8") GVRS-16-250-GG (10", 12") GVRS1-250 (2" to 24") GVRS1-16 (2" to 24")
NRS	GVNR 300 (2.5" to 12") GVNR-16-300 (2.5" to 8") GVNR-16-250 (10" & 12") GVNR-300-GG (2" to 12") GVNR-16-300-GG (2" to 8") GVNR-16-250-GG (10", 12")

MAXIMUM WORKING PRESSURE	As per Table-1
TEMPERATURE RATING	0 - 80°C
FACTORY HYDRO TEST PRESSURE	As per Table-1
SIZE	2" To 24" (50 To 600 mm)
END CONNECTION	As per Table-1
FINISH	Red Fusion Bonded Epoxy Coated Inside and Outside
APPROVALS	UL Listed & FM Approved Manufacturing Standard AWWA C515, BS 5163 (Ref. Table-1)
ORDERING INFORMATION	Model, Size and Flange Connection (ANSI/BS)

DESCRIPTION

HD Ductile Iron Gate Valves are available as OS&Y Type with rising stem and as NRS type with non-rising stem. Gate valves are designed to be the control valves in many of fire protection systems. Gate valves have flanged end connections, either ANSI/AWWA or BS PN16. HD Gate valves are fusion bonded epoxy coated, externally as well as internally, for fire protection application.

Outside screw and yoke (OS&Y) gate valves are recommended when positive shutoff and a quick visual indicator of open/closed position is required. These can be easily fitted with OS&Y Tamper switch. HD Gate valves are UL Listed and FM Approved.



TABLE-1

TYPE	MODEL NUMBER	MAXIMUM WORKING PRESSURE	FACTORY HYDRO TEST	END CONNECTION	APPROVALS	
OS&Y	GVRS 300	300 psi (21 bar)	Shell 600 psi Seal 450 psi	Flanged - ANSI B16.1/ AWWA	UL Listed & FM Approved. Manufacturing Standard AWWA C515, BS 5163	
	GVRS-300-GG			Grooved		
	GVRS-16-300	232 psi (16 bar)	Shell 464 psi Seal 348 psi	Flanged - BS EN 1092 PN16		
	GVRS-16-250			Flanged - BS EN 1092 PN16		
	GVRS-16-300-GG			Grooved		
	GVRS-16-250-GG			Grooved		
	GVRS1-250	250 psi (17.5 bar)	Shell 500 psi Seal 450 psi	Flanged - ANSI B16.1/ AWWA		UL Listed
	GVRS1-16	232 psi (16 bar)	Shell 464 psi Seal 348 psi	Flanged - BS EN 1092 PN16		
NRS	GVNR 300	300 psi (21 bar)	Shell 600 psi Seal 450 psi	Flanged - ANSI B16.1/ AWWA	UL Listed & FM Approved. Manufacturing Standard AWWA C515, BS 5163	
	GVNR-300-GG			Grooved		
	GVNR-16-300	232 psi (16 bar)	Shell 464 psi Seal 348 psi	Flanged - BS EN 1092 PN16		
	GVNR-16-250			Flanged - BS EN 1092 PN16		
	GVNR-16-300-GG			Grooved		
	GVNR-16-250-GG			Grooved		

INSTALLATION INSTRUCTIONS

- Gate valves should be properly cleaned and free from ingress of debris and foreign materials. Before installation wipe away dirt and grit from grit of the valve.
- Visually inspect the gate valve seating and ports for cleanliness prior to installation.
- All gate valves should be independently supported against movement and stress from the connected piping system.
- Ensure that the valve pressure rating is compatible with service conditions.
- Operate the gate valve at least once from the open to closed position before use.
- Verify that packing nuts are tight, before pressurizing the system.
- Open the valve about four to five turns and allow water flow to flush away any trash and debris from the line.
- Gate valves are not suitable for water throttling applications.
- Gate valves should be installed in the vertical position on horizontal pipework and in the horizontal position on vertical pipework.
- Piping systems should be supported and aligned to avoid damage to the valve.
- On completion of the installation, valve location, size, date of installation, number of turns to open, direction of opening, and other information deemed pertinent should be entered on permanent records.
- It is not advisable to use any valve in applications where either the pressure or temperature is higher than the allowable working values.
- Also valves should not be used in service media if not compatible with the valve material of construction, as this will lead to chemical issues in the valve.
- HD Make Gate valves are generally bi-directional, and therefore may be installed in either direction; unless a directional mark is mentioned on the valve body.

OPERATIONAL INSTRUCTIONS

Gate Valves must be used only in fully opened or fully closed position. Gate Valves are manually operated multi-turn valves and are opened by a hand wheel in a counter clockwise direction and then closed clockwise direction. Each valve should be operated through a full cycle and returned to its normal position, at least once in a year.

UNLOADING GATE VALVES ON SITE

1. Gate valves should be unloaded carefully. Each valve should be carefully lowered from the truck to the ground.
2. Gate valves should not be dropped. In the case of larger valves, forklifts or slings around the body of the valve or under the skids, should be used for unloading.
3. Hoists and slings with adequate load capacity to handle the weight of the valve or valves should be used.

INSPECTION AND MAINTENANCE

1. HD Gate valves require no routine or regular maintenance, apart from annual operation test.
2. All HD Gate valves should be operated for open and close cycle at least once in a year, to prevent stem binding due to rust or encrustation.
3. In the event of a packing leak, adjust the packing nuts to increase pressure on the stem packing. Packing nuts should be tightening evenly, approximately a quarter turn in a clockwise direction.
4. Always shut down the system before repacking the valve. Valves are designed with back seats for repacking under pressure but this is not recommended.

SPARE PARTS

HD Fire Protect does not recommend stocking any repair parts for its OS&Y Gate valves. Please contact HD Sales for any specific spare parts requirement.

GQRS 300

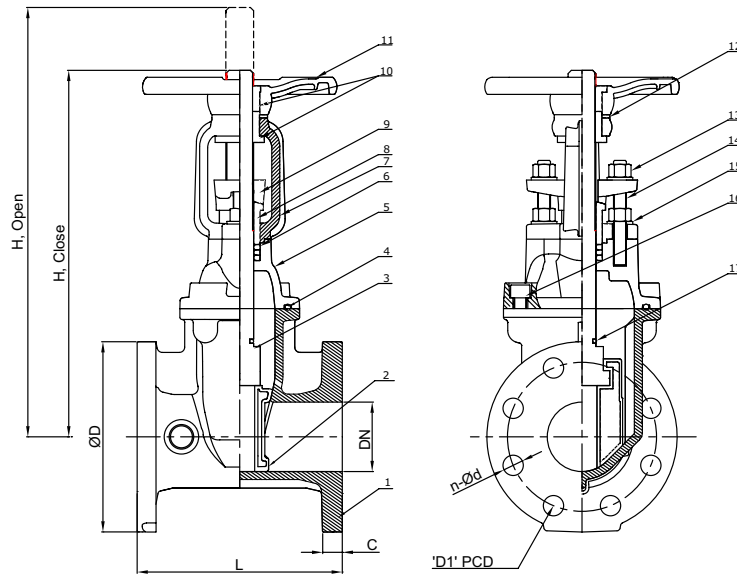

Sr. No.	Description	Material
1	Valve Body	ASTM A536, 65-45-12
2	Resilient Wedge Disc	ASTM A536, 65-45-12+EPDM
3	Stem	AISI 420
4	Bonnet Gasket	EPDM
5	Bonnet	ASTM A536, 65-45-12
6	Washer	Brass Hpb59-1
7	YOKE	ASTM A536, 65-45-12
8	Stem Bushing	Brass Hpb59-1
9	Gland	ASTM A536, 65-45-12
10	Stem Nut	Brass Hpb59-1
11	Handwheel	ASTM A536, 65-45-12
12	Washer	Brass Hpb59-1
13	Gland Nut	Carbon Steel Zinc plated
14	Stud	Carbon Steel Zinc plated
15	Flat Washer	Carbon Steel Zinc plated
16	Nut	Carbon Steel Zinc plated
17	O-Ring	EPDM

Size (DN)		Dimensions (MM)						
Inch	MM	L	H (close)	H (open)	D	D1	C	n-Ø d
2"	50	178	318	370	152	120.7	16	4-Ø 19.1
2.5"	65	190	343	410	178	139.7	17.5	4-Ø 19.1
3"	80	203	386	468	191	152.4	19.1	4-Ø 19.1
4"	100	229	436	538	229	190.5	19.1	8-Ø 19.1
5"	125	254	516	640	254	215.9	19.1	8-Ø 22.2
6"	150	267	576	730	279	241.3	19.1	8-Ø 22.2
8"	200	292	749	950	343	298.5	22.2	8-Ø 22.2
10"	250	330	904	1158	406	362	23.8	12-Ø 25.4
12"	300	356	1030	1335	483	431.8	25.4	12-Ø 25.4

GVRS-300-GG

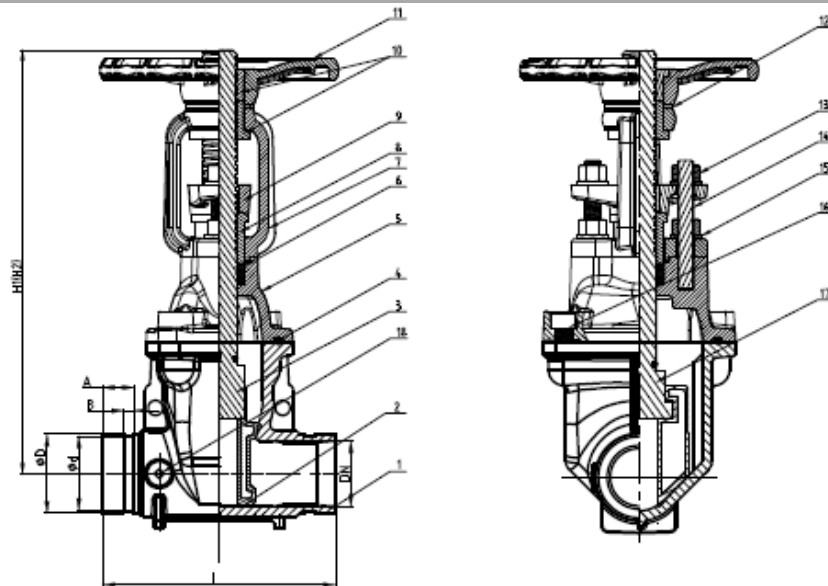

Sr. No.	Description	Material
1	Valve Body	Ductile Iron 65-45-12
2	Resilient Wedge Disc	Ductile Iron 65-45-12+EPDM
3	Stem	Stainless Steel 2Cr13
4	Bonnet Gasket	EPDM
5	Bonnet	Ductile Iron 65-45-12
6	Washer	C22000
7	Yoke	Ductile Iron 65-45-12
8	Stem Nut	Brass C22000
9	Gland flange	Ductile Iron 65-45-12
10	Wedge Nut	Brass C22000
11	Handwheel	Ductile Iron 65-45-12
12	Washer	C22000
13	Gland Nut	Carbon Steel Zinc Plated
14	Stud	Carbon Steel Zinc Plated
15	Flat Washer	Carbon Steel Zinc Plated
16	Bolt	Carbon Steel Zinc Plated
17	O-Ring	EPDM
18	Plug	ASTM B62 C83600

Size (DN)		Dimensions (mm)						
Inch	MM	L	H1 (close)	H2 (open)	ØD	Ød	A	B
2"	50	178	348	400	60.3	57.15	15.88	7.92
2.5"	65	190	373	440	73	69.09	15.88	7.92
3"	80	203	408	490	88.9	84.94	15.88	7.92
4"	100	229	471	573	114.3	110.08	15.88	9.52
5"	125	254	541	665	141.3	137.03	15.88	9.52
6"	150	267	601	755	168.3	163.96	15.88	9.52
8"	200	292	774	975	219.1	214.40	19.05	11.13
10"	250	330	939	1193	273.0	268.28	19.05	12.70
12"	300	356	1065	1370	323.9	318.29	19.05	12.70

GVR-16-300 AND GVR-16-250

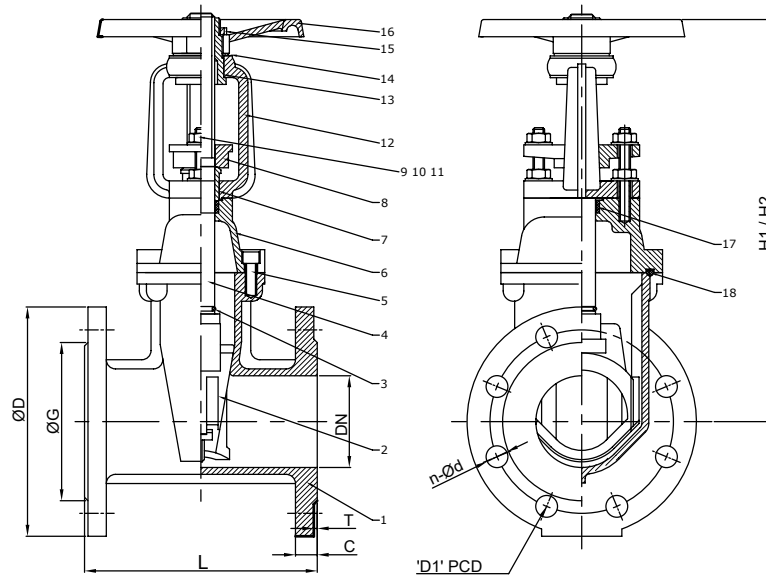

Sr. No.	Description	Material
1	Valve Body	EN-GJS-450-10
2	Resilient Wedge Disc	EN-GJS-450-10+EPDM
3	O-Ring	NBR
4	Stem	SS 420
5	Nut	Carbon Steel Zinc plated
6	Bonnet	EN-GJS-450-10
7	Stem Bushing	Brass Hpb59-1
8	Gland	EN-GJS-450-10
9	Flat Washer	Carbon Steel Zinc plated
10	Stud	Carbon Steel Zinc plated
11	Nut	Carbon Steel Zinc plated
12	Yoke	EN-GJS-450-10
13	Nut	Brass Hpb59-1
14	Washer	Brass Hpb59-1
15	Locknut	Carbon Steel Zinc plated
16	Handwheel	EN-GJS-450-10
17	Stem	NBR
18	Bonnet Gasket	EPDM

Size (DN)		Dimensions (mm)								
Inch	MM	L	H1 (close)	H2 (open)	D	D1	G	C	T	n-Ø d
2"	50	178	257	307	165	125	99	19	3	4-Ø 19
2.5"	65	190	305	370	185	145	118	19	3	4-Ø 19
3"	80	203	350	430	200	160	132	19	3	8-Ø 19
4"	100	229	422	522	220	180	156	19	3	8-Ø 19
5"	125	254	515	640	250	210	184	19	3	8-Ø 19
6"	150	267	563	713	285	240	211	19	3	8-Ø 23
8"	200	292	675	875	340	295	266	19	3	12-Ø 23
10"	250	330	905	1155	405	355	319	22	3	12-Ø 28
12"	300	356	1030	1330	460	410	370	24.5	4	12-Ø 28

GVRs-16-300-GG AND GVRs-16-250-GG

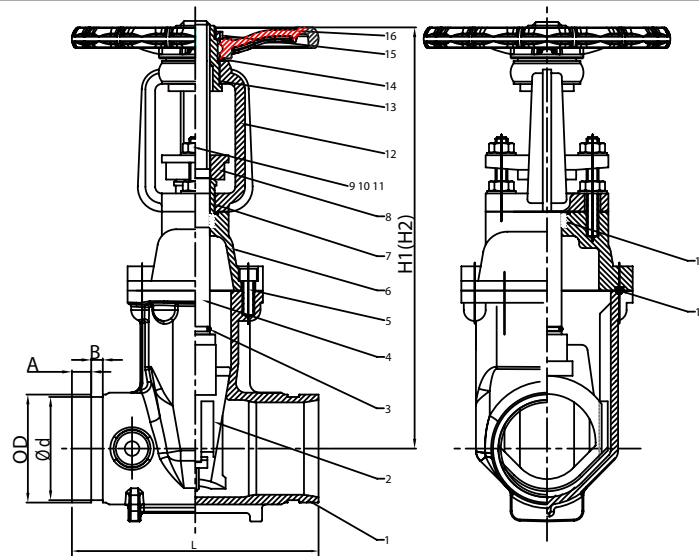

Sr. No.	Description	Material (Standard Specification)	Options
1	Valve Body	EN-GJS-450-10	
2	Resilient Wedge Disc	EN-GJS-450-10+EPDM	
3	O-Ring	NBR	EPDM
4	Stem	SS420	SS304, SS316, SS431
5	Bolt	Carbon Steel Zinc Plated	SS304, SS316
6	Bonnet	EN-GJS-450-10	
7	Stem Bushing	Brass HPb59-1	
8	Gland	EN-GJS-450-10	
9	Flat Washer	Carbon Steel Zinc Plated	SS304, SS316
10	Stud	Carbon Steel Zinc Plated	SS304, SS316
11	Nut	Carbon Steel Zinc Plated	SS304, SS316
12	Yoke	EN-GJS-450-10	
13	Stem Nut	Brass HPb59-1	
14	Washer	Brass HPb59-1	
15	Lock Nut	Carbon Steel Zinc Plated (Type A) Not available (Type B)	
16	Handwheel	EN-GJS-450-10	
17	Stem Packing	EPDM	NBR
18	Bonnet Gasket	EPDM	NBR

Size (DN)		Dimensions (mm)						
Inch	MM	L	H1 (Close)	H2 (Open)	OD	Ød	A	B
2"	50	178	323	373	60.3	57.15	15.88	7.93
2.5"	65	190	343	408	73	69.09	15.88	7.93
2.5"	65	190	343	408	76.1	72.26	15.88	7.93
3"	80	203	370	450	88.9	84.94	15.88	7.93
4"	100	229	442	542	114.3	110.08	15.88	9.53
5"	125	254	541	665	139.7	135.48	15.88	9.53
5"	125	254	541	665	141.3	137.03	15.88	9.53
6"	150	267	608	758	159	154.5	15.88	9.53
6"	150	267	608	758	165.1	160.9	15.88	9.53
6"	150	267	608	758	168.3	163.96	15.88	9.53
8"	200	292	720	920	219.1	214.40	19.05	11.13
10"	250	330	939	1193	273	268.28	19.05	12.7
12"	300	356	1065	1370	323.9	318.29	19.05	12.7

GVRS1-250

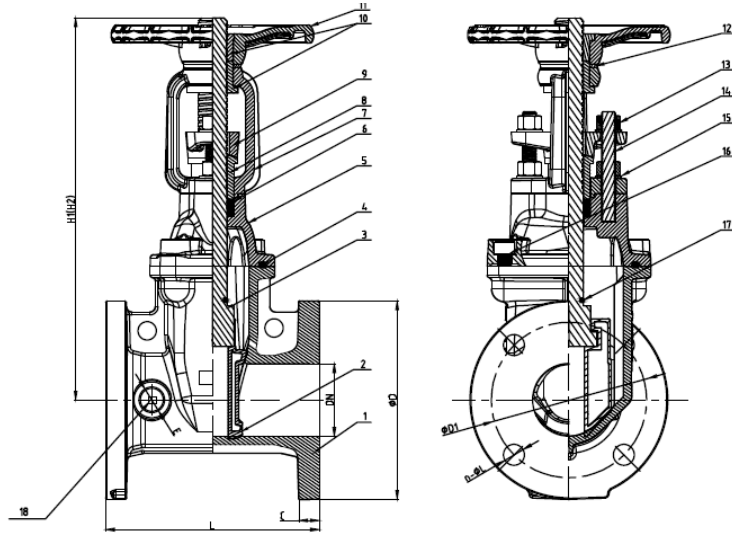

Sr. No.	Description	Material
1	Valve Body	ASTM A536, 65-45-12
2	Resilient Wedge Disc	ASTM A536, 65-45-12+EPDM
3	Stem	Stainless Steel 2Cr13
4	Bonnet Gasket	EPDM
5	Bonnet	ASTM A536, 65-45-12
6	Packing	EPDM
7	Yoke	ASTM A536, 65-45-12
8	Stem Bushing	Brass Hpb59-1
9	Gland	ASTM A536, 65-45-12
10	Stem Nut	Brass Hpb59-1
11	Handwheel	ASTM A536, 65-45-12
12	Washer	Brass Hpb59-1
13	Gland Nut	Carbon Steel Zinc plated
14	Stud	Carbon Steel Zinc plated
15	Flat Washer	Carbon Steel Zinc plated
16	Bolt	Carbon Steel Zinc plated
17	O-Ring	NBR
18	Plug	C89833

DN		Dimensions (mm)													
		L		H1(Close)		H2 (Open)		D		D1		C		n-ØL	
Inch	mm	Inch	mm	Inch	mm	Inch	mm	Inch	mm	Inch	mm	Inch	mm	Inch	mm
2"	50	7.01	178	13.70	348	15.75	400	5.98	152	4.75	120.7	0.63	16	4-Ø0.75	4-Ø19.1
2.5"	65	7.48	190	14.69	373	17.32	440	7.01	178	5.50	139.7	0.69	17.5	4-Ø0.75	4-Ø19.1
3"	80	7.99	203	16.06	408	19.29	490	7.52	191	6.00	152.4	0.75	19.1	4-Ø0.75	4-Ø19.1
4"	100	9.02	229	18.54	471	22.56	573	9.02	229	7.50	190.5	0.75	19.1	8-Ø0.75	8-Ø19.1
5"	125	10.00	254	21.30	541	26.18	665	10.00	254	8.50	215.9	0.75	19.1	8-Ø0.87	8-Ø22.2
6"	150	10.51	267	23.66	601	29.72	755	10.98	279	9.50	241.3	0.75	19.1	8-Ø0.87	8-Ø22.2
8"	200	11.50	292	30.47	774	38.39	975	13.50	343	11.75	298.5	0.87	22.2	8-Ø0.87	8-Ø22.2
10"	250	12.99	330	40.51	1029	50.51	1283	15.98	406	14.25	362	0.94	23.8	12-Ø1	12-Ø25.4
12"	300	14.02	356	41.93	1065	53.94	1370	19.02	483	17.00	431.8	1.00	25.4	12-Ø1	12-Ø25.4
14"	350	15.00	381	47.64	1210	61.42	1560	20.98	533	18.75	476.3	1.00	25.4	12-Ø1.13	12-Ø28.6
16"	400	15.98	406	50.39	1280	66.14	1680	23.50	597	21.25	539.8	1.00	25.4	12-Ø1.13	16-Ø28.6
18"	450	17.01	432	69.29	1760	87.01	2210	25.00	635	22.75	577.9	1.00	25.4	16-Ø1.25	16-Ø31.8
20"	500	17.99	457	70.08	1780	89.76	2280	27.52	699	25.00	635	1.13	28.6	16-Ø1.25	20-Ø31.8
24"	600	20.00	508	76.77	1950	100.39	2550	32.01	813	29.50	749.3	1.19	30.1	20-Ø1.37	20-Ø34.9

GVR51-16

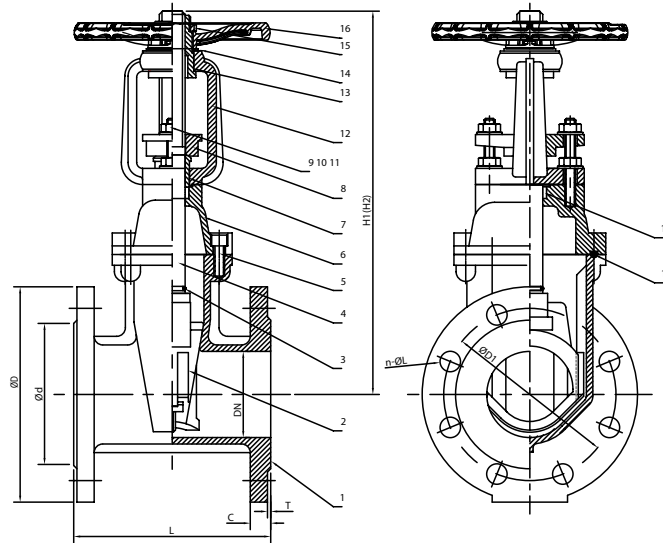

Sr. No.	Description	Material	Options
1	Valve Body	EN-GJS-450-10	
2	Resilient Wedge Disc	EN-GJS-450-10+EPDM	
3	O-Ring	NBR	EPDM
4	Stem	SS420	SS304, SS316, SS431
5	Bolt	Carbon Steel Zinc Plated	SS304, SS316
6	Bonnet	EN-GJS-450-10	
7	Stem Bushing	Brass HPb59-1	
8	Gland	EN-GJS-450-10	
9	Flat Washer	Carbon Steel Zinc Plated	SS304, SS316
10	Stud	Carbon Steel Zinc Plated	SS304, SS316
11	Nut	Carbon Steel Zinc Plated	SS304, SS316
12	Yoke	EN-GJS-450-10	
13	Stem Nut	Brass HPb59-1	
14	Washer	Brass HPb59-1	
15	Lock Nut	Carbon Steel Zinc Plated (Type A) Not Available (Type B)	
16	Hand Wheel	EN-GJS-450-10	
17	Stem Packing	EPDM	NBR
18	Bonnet Gasket	EPDM	NBR

DN		PN	Dimensions (mm)										
Inch	mm		L	Type A		Type B		D	D1	d	C	T	n-ØL
		H1 (Close)		H2 (Open)	H1 (Close)	H2 (Open)							
2"	50	10/16	178	323	373	348	400	165	125	99	19	3	4-Ø19
2.5"	65	10/16	190	343	408	373	440	185	145	118	19	3	4-Ø19
3"	80	10/16	203	370	450	408	490	200	160	132	19	3	4-Ø19
4"	100	10/16	229	442	542	471	573	220	180	156	19	3	8-Ø19
5"	125	10/16	254	541	665	541	665	250	210	184	19	3	8-Ø19
6"	150	10/16	267	608	758	601	755	285	240	211	19	3	8-Ø23
8"	200	10	292	720	920	774	975	340	295	266	20	3	8-Ø23
		16											12-Ø23
10"	250	10	330	939	1193	939	1193	405	350	319	22	3	12-Ø23
		16							355				12-Ø28
12"	300	10	356	1065	1370	1065	1370	460	400	370	24.5	4	12-Ø23
		16							410				12-Ø28
14"	350	10	381	1210	1560	1210	1560	520	460	429	26.5	4	16-Ø23
		16							470				16-Ø28
16"	400	10	406	1280	1680	1280	1680	580	515	480	28	4	16-Ø28
		16							525				16-Ø31
18"	450	10	432	1760	2210	1760	2210	640	565	530	30	4	20-Ø28
		16							585				548
20"	500	10	457	1780	2280	1780	2280	715	620	582	31.5	4	20-Ø28
		16							650				609
24"	600	10	508	1950	2550	1950	2550	840	725	682	36	5	20-Ø31
		16							770				720

GVNR 300

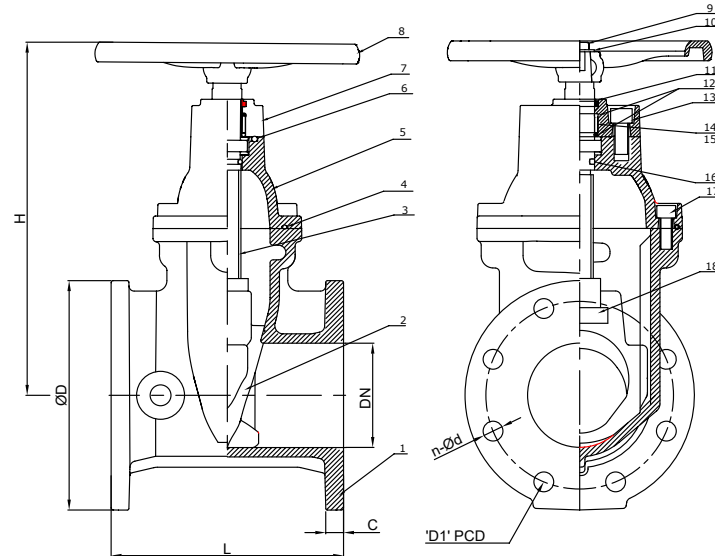

Sr. No.	Description	Material
1	Valve Body	ASTM A536, 65-45-12
2	Resilient Wedge Disc	ASTM A536, 65-45-12+EPDM
3	Stem	AISI 431
4	Bonnet Gasket	EPDM
5	Bonnet	ASTM A536, 65-45-12
6	O-Ring	EPDM
7	Gland	ASTM A536, 65-45-12
8	Handwheel	ASTM A536, 65-45-12
9	Bolt	Carbon Steel Zinc plated
10	Flat Washer	Carbon Steel Zinc plated
11	Ring Wiper	EPDM
12	O-Ring	NBR
13	Nut	Carbon Steel Zinc plated
14	Axis Guide	Brass Hpb59-1
15	Washer	Brass Hpb59-1
16	O-Ring	NBR
17	Nut	Carbon Steel Zinc plated
18	Wedge Nut	Brass Hpb59-1

Size (DN)		Dimensions (MM)					
Inch	MM	L	H	D	D1	C	n-Ø d
2"	50	178	254	152	102.7	16	4-Ø 19.1
2.5"	65	190	275	178	139.7	17.5	4-Ø 19.1
3"	80	203	301	191	152.4	19.1	4-Ø 19.1
4"	100	229	355	229	190.5	19.1	8-Ø 19.1
5"	125	254	393	254	215.9	19.1	8-Ø 22.2
6"	150	267	448	279	241.3	19.1	8-Ø 22.2
8"	200	292	548	343	298.5	22.2	8-Ø 22.2
10"	250	330	626	406	362	23.8	12-Ø 25.4
12"	300	356	722	483	431.8	25.4	12-Ø 25.4

GVNR-300-GG

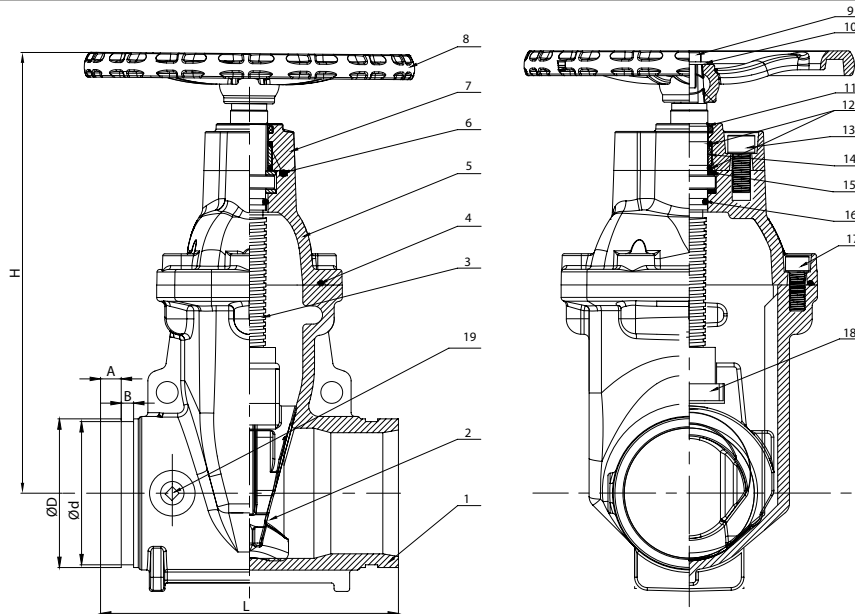

Sr. No.	Description	Material
1	Valve Body	ASTM A536, 65-45-12
2	Resilient Wedge Disc	ASTM A536, 65-45-12+EPDM
3	Stem	Stainless Steel
4	Bonnet Gasket	EPDM
5	Bonnet	ASTM A536, 65-45-12
6	O-Ring	NBR
7	Gland	ASTM A536, 65-45-12
8	Handwheel	ASTM A536, 65-45-12
9	Bolt	Carbon Steel Zinc plated
10	Flat Washer	Carbon Steel Zinc plated
11	Ring Wiper	EPDM
12	O-Ring	NBR
13	Bolt	Carbon Steel Zinc plated
14	Axis Guide	Brass Hpb59-1
15	Washer	Brass Hpb59-1
16	O-Ring	NBR
17	Bolt	Carbon Steel Zinc plated
18	Wedge Nut	Brass Hpb59-1
19	Plug	ASTM B584-06a C89833

DN		Dimensions (Inch)					
Inch	MM	L	H	ØD	Ød	A	B
2"	50	7.00	10.00	2.375	2.250	0.625	0.312
2.5"	65	7.48	10.83	2.875	2.750	0.625	0.312
3"	80	8.00	11.85	3.500	3.344	0.625	0.312
4"	100	9.00	13.98	4.500	4.334	0.625	0.375
5"	125	10.00	15.47	5.563	5.395	0.625	0.375
6"	150	10.50	17.64	6.625	6.455	0.625	0.375
8"	200	11.50	21.57	8.625	8.441	0.750	0.438
10"	250	13.00	24.65	10.750	10.562	0.750	0.500
12"	300	14.00	28.43	12.750	12.531	0.750	0.500

GVNR-16-300 AND GVNR-16-250

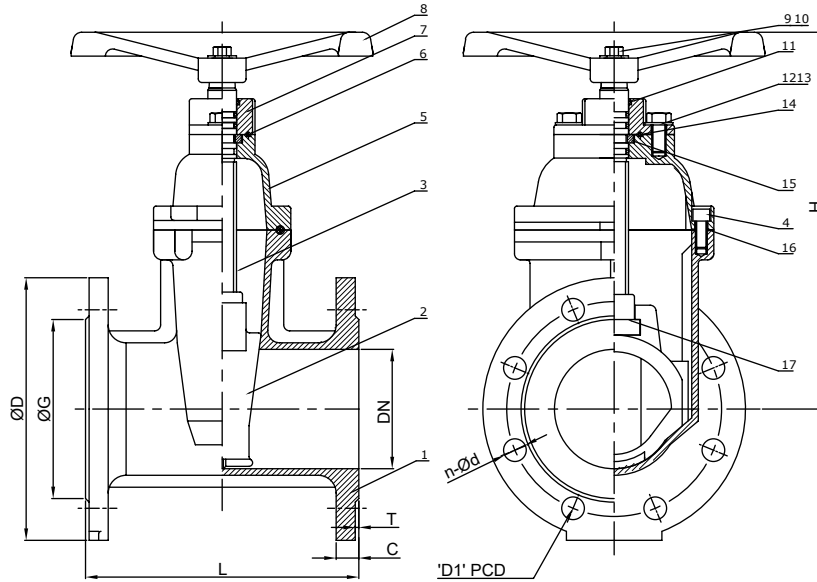

Sr. No.	Description	Material
1	Valve Body	EN-GJS-450-10
2	Resilient Wedge Disc	EN-GJS-450-10+EPDM
3	Stem	SS 420
4	Nut	Carbon Steel Zinc plated
5	Bonnet	EN-GJS-450-10
6	O-Ring	NBR
7	Gland Stem	EN-GJS-450-10
8	Handwheel	EN-GJS-450-10
9	Bolt	Carbon Steel Zinc plated
10	Flat Washer	Carbon Steel Zinc plated
11	Ring Wiper	NBR
12	Bolt	Carbon Steel Zinc plated
13	Flat Washer	Carbon Steel Zinc plated
14	O-Ring	NBR
15	Thrust Washer	Brass Hpb59-1
16	Bonnet Gasket	EPDM
17	Wedge Nut	NBR

Size (DN)		Dimensions (mm)							
Inch	MM	L	H	D	D1	G	C	T	n-Ø d
2"	50	178	257	165	125	99	19	3	4-Ø 19
2.5"	65	190	305	185	145	118	19	3	4-Ø 19
3"	80	203	350	200	160	132	19	3	8-Ø 19
4"	100	229	422	220	180	156	19	3	8-Ø 19
5"	125	254	515	250	210	184	19	3	8-Ø 19
6"	150	267	563	285	240	211	19	3	8-Ø 23
8"	200	292	675	340	295	266	19	3	12-Ø 23
10"	250	330	905	405	355	319	22	3	12-Ø 28
12"	300	356	1030	460	410	370	24.5	4	12-Ø 28

GVNR-16-300-GG AND GVNR-16-250-GG

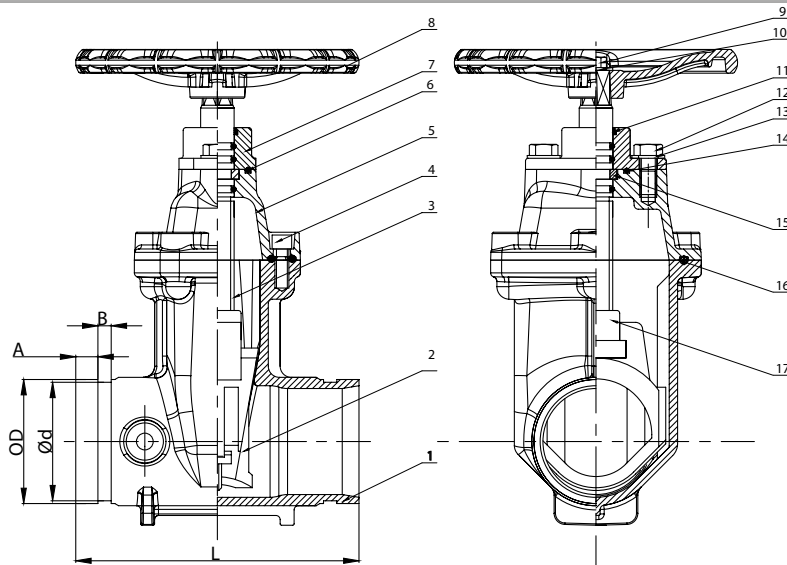

Sr. No.	Description	Material	Options
1	Valve Body	EN-GJS-450-10	
2	Resilient Wedge Disc	EN-GJS-450-10+EPDM	
3	Stem	SS 420	SS304, SS316, SS431
4	Bolt	Carbon Steel Zinc plated	SS304, SS316
5	Bonnet	EN-GJS-450-10	
6	O-Ring	NBR	EPDM
7	Gland	EN-GJS-450-10	
8	Handwheel	EN-GJS-450-10	
9	Bolt	Carbon Steel Zinc plated	SS304, SS316
10	Flat Washer	Carbon Steel Zinc plated	SS304, SS316
11	Ring Wiper	EPDM	NBR
12	Bolt	Carbon Steel Zinc plated	SS304, SS316
13	Flat Washer	Carbon Steel Zinc plated	SS304, SS316
14	O-Ring	NBR	EPDM
15	Thrust Washer	Brass Hpb59-1	Bronze ZQSn5-5-5
16	Bonnet Gasket	EPDM	
17	Wedge Nut	Brass Hpb59-1	Bronze ZQSn5-5-5

Size (DN)		Dimensions (mm)					
Inch	MM	L	H	OD	d	A	B
2"	50	178	218	60.3	57.15	15.88	7.93
2.5"	65	190	230	73	69.09	15.88	7.93
2.5"	65	190	230	76.1	72.26	15.88	7.93
3"	80	203	281	88.9	84.94	15.88	7.93
4"	100	229	316	114.3	110.08	15.88	9.53
5"	125	254	393	139.7	135.48	15.88	9.53
5"	125	254	393	141.3	137.03	15.88	9.53
6"	150	267	420	159	154.5	15.88	9.53
6"	150	267	420	165.1	160.9	15.88	9.53
6"	150	267	420	168.3	163.96	15.88	9.53
8"	200	292	490	219.1	214.4	19.05	11.13
10"	250	330	626	273	268.28	19.05	12.7
12"	300	356	722	323.9	318.29	19.05	12.7

LIMITED WARRANTY

HD FIRE PROTECT PVT. LTD. hereby referred to as HD FIRE warrants to the original purchaser of the fire protection products manufactured by HD FIRE and to any other person to whom such equipment is transferred, that such products will be free from defect in material and workmanship under normal use and care, for two (2) years from the date of shipment by HD FIRE. Products or Components supplied or used by HD FIRE, but manufactured by others, are warranted only to the extent of the manufacturer's warranty. No warranty is given for product or components which have been subject to misuse, improper installation, corrosion, unauthorized repair, alteration or un-maintained. HD FIRE shall not be responsible for system design errors or improper installation or inaccurate or incomplete information supplied by buyer or buyer's representatives. HD FIRE will repair or replace defective material free of charge, which is returned to our factory, transportation charge prepaid, provided after our inspection the material is found to have been defective at the time of initial shipment from our works. HD FIRE shall not be liable for any incidental or consequential loss, damage or expense arising directly or indirectly from the use of the product including damages for injury to person, damages to property and penalties resulting from any products and components manufactured by HD FIRE. HD FIRE shall not be liable for any damages or labour charges or expense in making repair or adjustment to the product. HD FIRE shall not be liable for any damages or charges sustained in the adaptation or use of its engineering data & services. In no event shall HD Fire's product liability exceed an amount equal to the sale price. The foregoing warranty is exclusive and in lieu of all other warranties and representation whether expressed, implied, oral or written, including but not limited to, any implied warranties or merchantability or fitness for a particular purpose. All such other warranties and representations are hereby cancelled.

NOTICE :

The equipment presented in this bulletin is to be installed in accordance with the latest publication standards of NFPA or other similar organisations and also with the provision of government codes or ordinances wherever applicable.

The information provided by us is to the best of our knowledge and belief, and consist of general guidelines only. Site handling and installation control is not in our scope. Hence we give no guarantee for result and take no liability for damages, loss or penalties whatsoever, resulting from our suggestion, information, recommendation or damages due to our product.

Product development is a continuous programme of HD FIRE PROTECT PVT. LTD. and hence the right to modify any specification without prior notice is reserved with the company.



HD FIRE PROTECT PVT. LTD.
Protecting What Matters Most to You

D-6/2, ROAD NO. 34, WAGLE INDUSTRIAL ESTATE, THANE 400 604, INDIA.

• TEL: + (91) 22 2158 2600 • FAX: +(91) 22 2158 2602
• EMAIL: info@hdfire.com • WEB: www.hdfire.com