

MONITOR - VAJRA 433 (CAST BRONZE)



TECHNICAL DATA

MODEL	VAJRA 433
NOMINAL SIZE	4 inch (100 mm)
MAX. SERVICE PRESSURE	175 psi (12 bar)
MAXIMUM FLOW	2000 gpm (7570 lpm)*
FACTORY HYDROSTATIC TEST PRESSURE	400 psi (27.6 bar)
SWIVEL JOINT	Bronze to IS:318 / ASTM B 62 with double row of Stainless Steel Ball Bearing and Grease Fittings
NOZZLE THRUST REACTION IN KG	Flow in lpm X $\sqrt{\text{Pressure}}$ in kg/sq.cm X 0.0228
INLET CONNECTION	4" or 6" (100 or 150NB) Flange to ANSI B16.24#150,F.F.
OUTLET CONNECTION	4" BSP (M)
MONITOR ELEVATION	90 deg. above horizontal & 65 deg. below horizontal
MONITOR ROTATION	360 deg. continuous
MONITOR MOVEMENT	Hand wheel driven fully enclosed worm gear
FINISH	Red RAL 3001
WEIGHT (Approx)	92 kg
ORDERING INFORMATION	Specify Monitor Model and Inlet Flange Size
APPROVAL	FM Approved

DESCRIPTION

Corrosion Resistant Bronze Monitor Model-VAJRA 433, is durable manual controlled monitor for fixed installation as well as trailer mounted unit. The monitor is generally used for protection of flammable liquid storage tanks, loading racks, dykes marine and many other Industrial application.

The monitor possess several design features that provides ease of operation, minimum maintenance and resistance to corrosive environments. The monitor is used with aspirating, non-aspirating and water nozzles with flow range upto 2000 gpm (7570 lpm).

The monitor has rugged, corrosion resistant cast bronze construction. The vertical and horizontal rotation is through corrosion resistant bronze swivel joints with double row of stainless steel ball bearing.



Both vertical and horizontal movements are controlled with handwheel driven fully enclosed worm gears and protected from the elements.

The monitor has large flow capability and can be manually operated by a single fire fighter. The design ensures to prevent jet reaction forces from effecting the horizontal and the vertical position of the monitor. The counter balance is not required to offset the weight of the nozzle. The monitor has the ability for 360 deg. continuous horizontal rotation and angle of elevation is 90 deg. above horizontal and 65 deg. below horizontal.

The water vanes in discharge tube reduces the turbulence and friction loss, thus increasing the nozzle performance to achieve greater range. To ensure desired performance, the friction loss through monitor must be considered while selecting the nozzle and the flow through the monitor with reference to available base pressure at inlet of the monitor. For flow and jet reach data refer monitor nozzle data sheet.

- Note:** (i) Pressure Gauge is optional supply
(ii) *For flow, refer VARSHA-50 FM approved nozzle Data Sheet No. HD173

INSTALLATION, TESTING AND MAINTENANCE

The monitor must be installed and operated carefully by a trained person, having good knowledge of equipment. Before assembly of the monitor to the supply piping, thoroughly flush the piping with water to avoid sand, residue, welding slag or other debris hindering the proper functioning of the monitor.

After few initial successful tests, an authorized person must be trained to perform the inspection and testing of the monitor.

The monitor should be ready for use. To achieve this condition, scheduled inspection and maintenance operation should be performed and it must be recorded in the maintenance register book indicating the requirement or recommendation. The recommended maintenance, procedure must be followed as given in the manual and also as per the local authority having jurisdiction.

It is recommended to carry out weekly physical inspection of the monitor. The inspection should verify that no damage has taken place to any component and the monitor is ready for use.

Carry out functional test every month for the flow, regular rotation in horizontal and vertical plane for the entire operating range to observe any leakage.

Periodic proper greasing through grease nipple provided on bearing, worm wheel and worm shaft must be ensured. Use water resistant low friction synthetic grease. Lubrication is required for smooth operation.

Each monitor must be operated with the full flow in accordance to the guidelines of the organisation having local jurisdiction.

The owner is responsible for maintaining the equipment in proper operating condition.

CAUTION

A trained personnel for fire fighting must use the monitor. Appropriate guidance & training must be given to reduce the risk or injury.

The nozzle must be fixed to the monitor carefully, The flange bolts must be tightened uniformly.

The piping must be able to with stand the horizontal reaction force. Serious injury to personnel and equipment can result from improper installation.

When installing monitor it is critical that flange bolts be tightened uniformly to prevent cocking of the monitor relative to the flange or valve.

Before flowing water from monitor, check that all personnel are out of stream path and stream direction will not cause avoidable property damage.

Application of water or foam on an electric appliance can cause serious injury.

The water supply to monitor must be increased/decreased gradually to prevent possible water hammer occurrence.

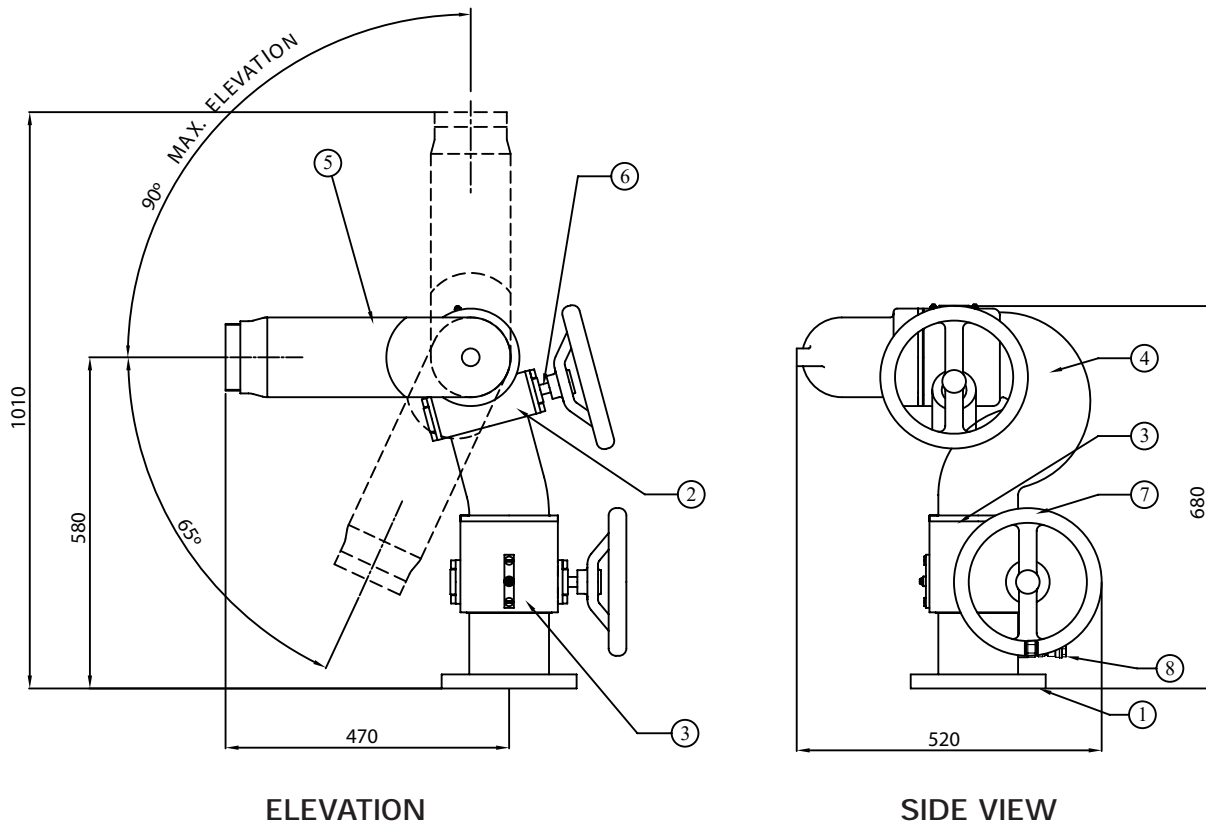

PART LIST

SR NO	DESCRIPTION	MATERIAL SPECIFICATION
1	BASE FLANGE	BRONZE IS:318/ASTM B62
2	WORM WHEEL	BRONZE IS:318/ASTM B62
3	SWIVEL JOINT V & H ROTATION	BRONZE IS:318/ASTM B62
4	ELBOW	BRONZE IS:318/ASTM B62
5	DISCHARGE ELBOW	BRONZE IS:318/ASTM B62
6	WORM SHAFT	STAINLESS STEEL
7	HAND WHEEL	CAST IRON
8	DRAIN VALVE	BRASS

Note :

- 1) Monitor inlet flange standard size is 100 NB (4") to ANSI B16.24, 150#, other sizes 150 NB (6") optional.
- 2) All dimensions in mm and are approximate.
- 3) Nozzle suitable to this Monitor is VARSHA 50 (FM Approved)
- 4) Pressure Guage is optional supply.

LIMITED WARRANTY

HD FIRE PROTECT PVT. LTD. hereby referred to as HD FIRE warrants to the original purchaser of the fire protection products manufactured by HD FIRE and to any other person to whom such equipment is transferred, that such products will be free from defect in material and workmanship under normal use and care, for two (2) years from the date of shipment by HD FIRE. Products or Components supplied or used by HD FIRE, but manufactured by others, are warranted only to the extent of the manufacturer's warranty. No warranty is given for product or components which have been subject to misuse, improper installation, corrosion, unauthorized repair, alteration or un-maintained. HD FIRE shall not be responsible for system design errors or improper installation or inaccurate or incomplete information supplied by buyer or buyer's representatives. HD FIRE will repair or replace defective material free of charge, which is returned to our factory, transportation charge prepaid, provided after our inspection the material is found to have been defective at the time of initial shipment from our works. HD FIRE shall not be liable for any incidental or consequential loss, damage or expense arising directly or indirectly from the use of the product including damages for injury to person, damages to property and penalties resulting from any products and components manufactured by HD FIRE. HD FIRE shall not be liable for any damages or labour charges or expense in making repair or adjustment to the product. HD FIRE shall not be liable for any damages or charges sustained in the adaptation or use of its engineering data & services. In no event shall HD Fire's product liability exceed an amount equal to the sale price. The foregoing warranty is exclusive and in lieu of all other warranties and representation whether expressed, implied, oral or written, including but not limited to, any implied warranties or merchantability or fitness for a particular purpose. All such other warranties and representations are hereby cancelled.

NOTICE :

The equipment presented in this bulletin is to be installed in accordance with the latest publication standards of NFPA or other similar organisations and also with the provision of government codes or ordinances wherever applicable.

The information provided by us is to the best of our knowledge and belief, and consist of general guidelines only. Site handling and installation control is not in our scope. Hence we give no guarantee for result and take no liability for damages, loss or penalties whatsoever, resulting from our suggestion, information, recommendation or damages due to our product.

Product development is a continuous programme of HD FIRE PROTECT PVT. LTD. and hence the right to modify any specification without prior notice is reserved with the company.



HD FIRE PROTECT PVT. LTD.
Protecting What Matters Most to You

D-6/2, ROAD NO. 34, WAGLE INDUSTRIAL ESTATE, THANE 400 604, INDIA.
• TEL: + (91) 22 2158 2600 • FAX: +(91) 22 2158 2602
• EMAIL: info@hdfire.com • WEB: www.hdfire.com