

RATIO CONTROLLER



TECHNICAL DATA

MODEL	Stainless Steel Construction: RCW-S, RCW-SM, RCF-S, RCF-SM Bronze Construction: RCW-B, RCW-BM RCF-B, RCF-BM
SIZE	65, 80, 100, 150 & 200 NB
MAXIMUM SERVICE PRESSURE	14 kg/cm ² (200 psi); 12.3 kg/cm ² (175 psi) for UL & FM Approved models
FACTORY HYDRO-STATIC TEST PRESSURE	24.6 kg/cm ² (350 psi)
MOUNTING	Between the flanges ANSI B16.5 - 150#
APPROVAL	UL Listed and FM Approved
FINISH	Red RAL 3001 or Natural Finish
ORDERING INFORMATION	Specify a) Model & Size b) Minimum and Maximum Pressure and flow rate c) Induction Percentage d) Type of Foam Concentrate used

DESCRIPTION

Ratio Controller is used for proportioning foam concentrate into the water supply with a wide range of flow and pressure. The Ratio Controller is also used with Bladder Tank Proportioning System, Inline Balance Proportioning System and Skid Mounted Pump Balance Proportioning System.

SPECIFICATION

The Ratio Controller works on venturi principle. As the water flow passes through nozzle at the inlet of ratio controller, a low-pressure area is created between inlet nozzle and the down stream section called diffuser. This low-pressure area causes the foam concentrate to flow through a metering orifice at the concentrate inlet and into the low-pressure area.

As the system demand varies, the water jet through Ratio Controller increases or decreases, which in turn varies the pressure at the low-pressure area of the Ratio Controller. This affects the corresponding pressure across the foam concentrate-metering orifice. The system requires same pressure of water and concentrate in order to balance the proportioning system.

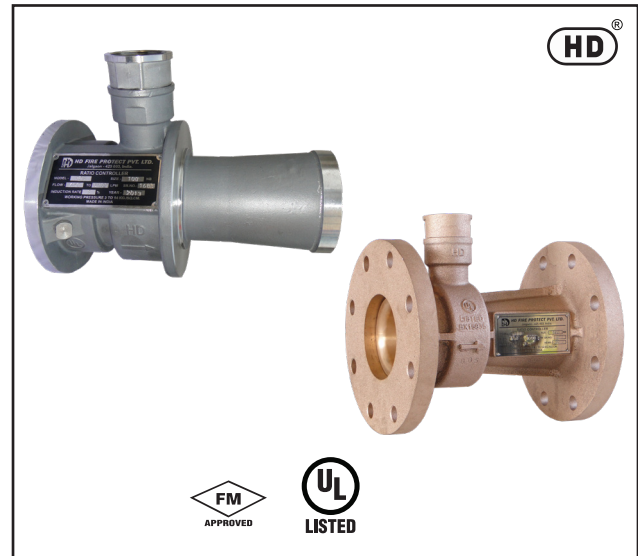

INSTALLATION

Ratio Controller Model RCW is wafer style to be mounted in SCH40 pipe between two flanges while Model RCF has flanged end connection. Flow direction arrow is marked on the Ratio Controller.

NOTE

- 1) A minimum of five pipe diameter of straight unobstructed pipe is required at upstream and downstream of each ratio controller.
- 2) Ratio Controller shall be installed between two ANSI 150# flanges with raised face or flat face. Gaskets, studs & flanges shall be provided by the installer.
- 3) Provision shall be made in piping for removal of Ratio Controller.
- 4) The pipes on upstream & downstream side of the Ratio Controller must be adequately supported and no strain shall be imposed on Ratio Controller.
- 5) Ratio Controller is UL Listed/ FM Approved with HD Bladder Tank, Refer to specific UL Listing / FM Approval data for more information.
- 6) Ratio Controller is UL Listed for 2.1 to 12 bar pressure.
- 7) For Flow data, when used with Inline Balance pressure proportioner, contact HD Fire Sales.

RATIO CONTROLLER (WAFER STYLE - RCW SERIES)

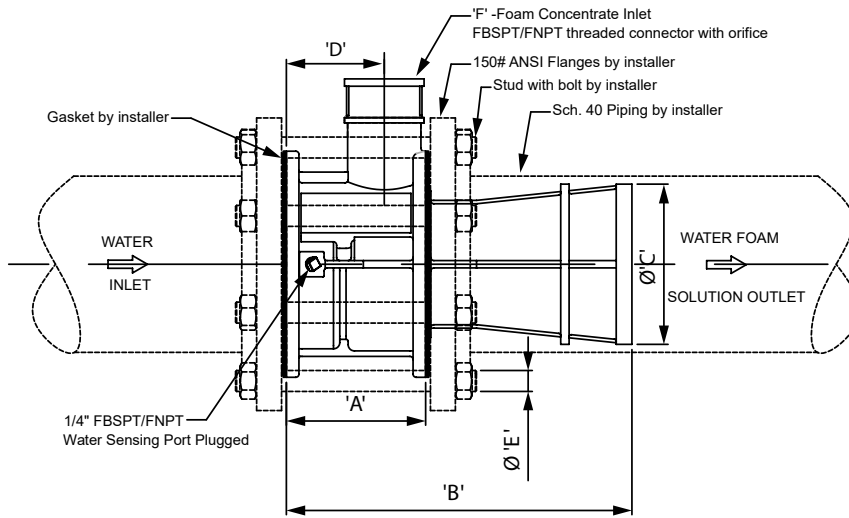

DIMENSIONS

Size	Approximate Dimensions (in mm)					
	'A'	'B'	Ø 'C'	'D'	Ø 'E'	'F'
2½"	80	190	Ø61.7	55	M16 x 170 LONG	1" BSPT (F)/NPT (F)
3"	107.5	190	Ø76	82.5	M16 x 200 LONG	1½" BSPT (F)/NPT (F)
4"	126	266	Ø101	90	M16 x 220 LONG	1½" BSPT (F)/NPT (F)
6"	133	330	Ø152	93.5	M20 x 230 LONG	2" BSPT (F)/NPT (F)
8"	130	340	Ø200	80	M20 X 240 LONG	2" BSPT (F)/NPT (F)

RATIO CONTROLLER (FLANGE STYLE - RCF SERIES)

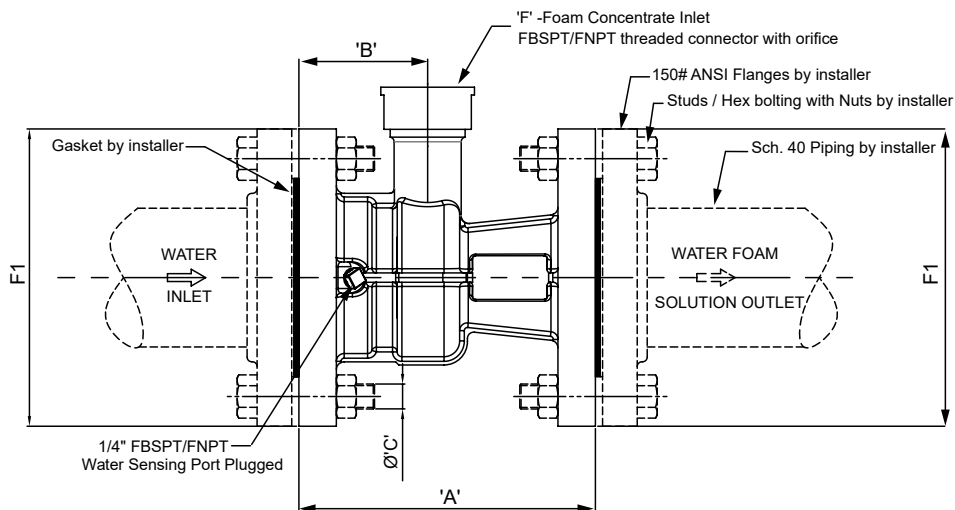

Dimensions of Inlet / Outlet Flanges (F1) is as per ANSI B16.5 #150

DIMENSIONS

Size	Approximate Dimensions (in mm)			
	'A'	'B'	Ø 'C'	'F'
2½"	190	55	M16	1" BSPT (F)/NPT (F)
3"	190	82.5	M16	1½" BSPT (F)/NPT (F)
4"	266	90	M16	1½" BSPT (F)/NPT (F)
6"	330	93.5	M20	2" BSPT (F)/NPT (F)
8"	340	80	M20	2" BSPT (F)/NPT (F)

UL LISTED RATIO CONTROLLER FLOW RANGE (LPM)

Size	Model		UL Listed	
	Wafer Style	Flange Style	AFFF 3%	AR-AFFF 3X3%
65 NB	RCW-B, RCW-S	RCF-B, RCF-S	100 TO 1550	421 TO 1460
	RCW-BM, RCW-SM	RCF-BM, RCF-SM	-----	160 TO 582
80 NB	RCW-B, RCW-S	RCF-B, RCF-S	260 TO 3000	787 TO 3060
	RCW-BM, RCW-SM	RCF-BM, RCF-SM	-----	-----
100 NB	RCW-B, RCW-S	RCF-B, RCF-S	650 TO 6000	1140 TO 6060
150 NB	RCW-B, RCW-S	RCF-B, RCF-S	1200 TO 12000	-----
	RCW-BM, RCW-SM	RCF-BM, RCF-SM	-----	2370 TO 12210
200 NB	RCW-B, RCW-S	RCF-B, RCF-S	2750 TO 17860	2320 TO 17500

FM APPROVED RATIO CONTROLLER FLOW RANGE (LPM)

Size	Model		FM Approved	
	Wafer Style	Flange Style	AFFF 3%	AR-AFFF 3X3%
65 NB	RCW-B, RCW-S	RCF-B, RCF-S	102 TO 1590	500 TO 1030
	RCW-BM, RCW-SM	RCF-BM, RCF-SM	-----	165 TO 528
80 NB	RCW-B, RCW-S	RCF-B, RCF-S	290 TO 2990	-----
	RCW-BM, RCW-SM	RCF-BM, RCF-SM	-----	820 TO 3080
100 NB	RCW-B, RCW-S	RCF-B, RCF-S	600 TO 6050	1810 TO 6140
150 NB	RCW-B, RCW-S	RCF-B, RCF-S	1200 TO 11460	5000 TO 12300
	RCW-BM, RCW-SM	RCF-BM, RCF-SM	-----	-----
200 NB	RCW-B, RCW-S	RCF-B, RCF-S	-----	-----

INLET PRESSURE VS FOAM SOLUTION FLOW
UL LISTED, MODEL RCW-B / RCW-S / RCF-B / RCF-S
(FOAM CONCENTRATE: AFFF 3%)

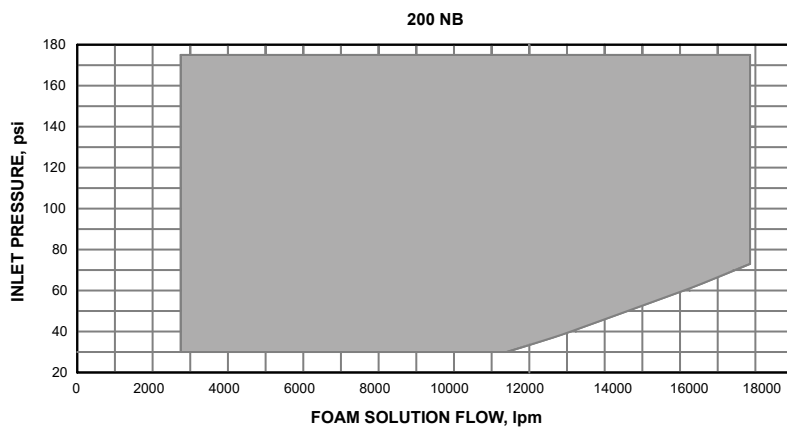
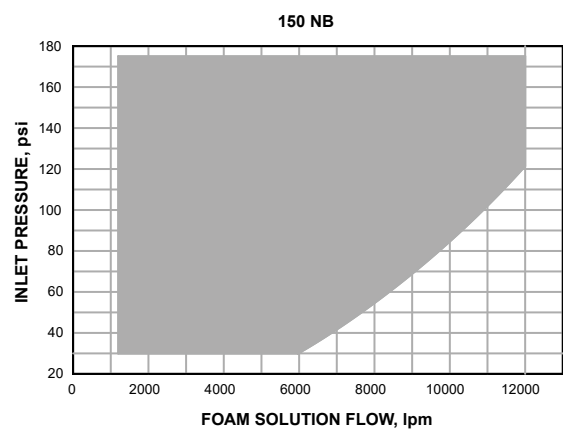
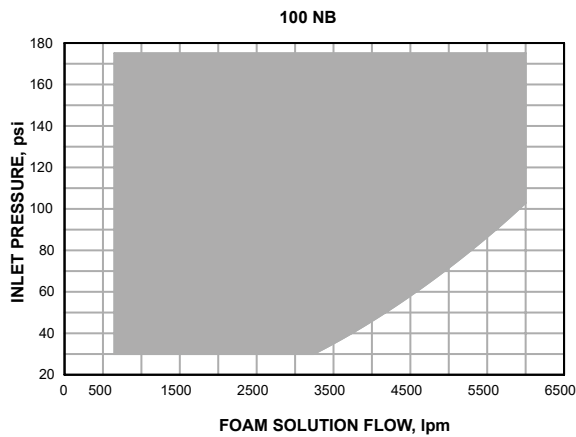
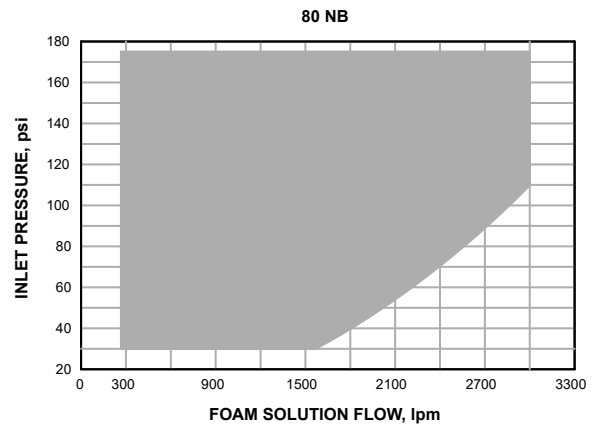
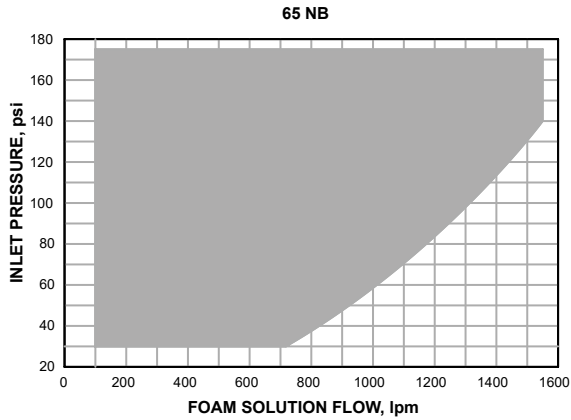

**INLET PRESSURE VS FOAM SOLUTION FLOW
UL LISTED
(FOAM CONCENTRATE: AR-AFFF 3X3%)**

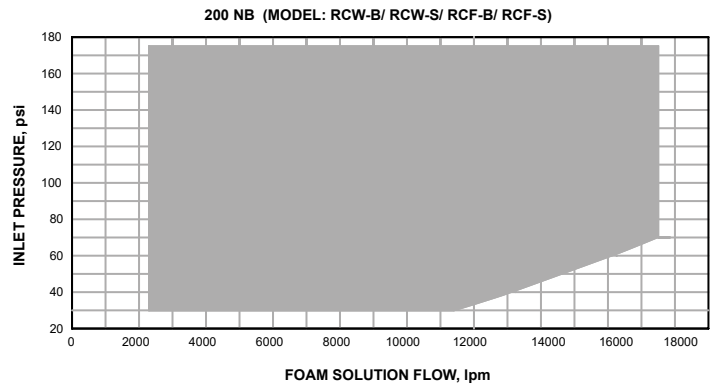
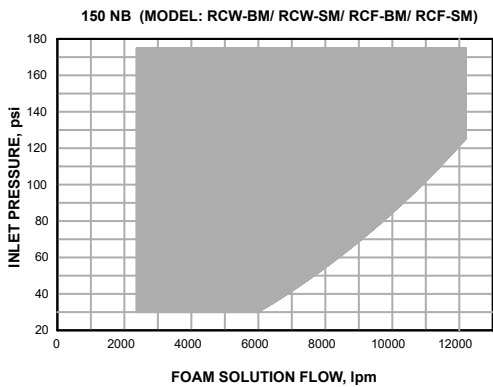
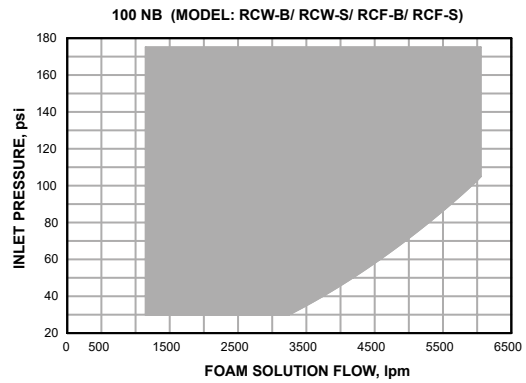
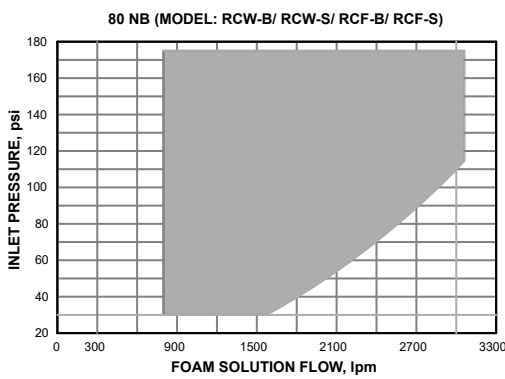
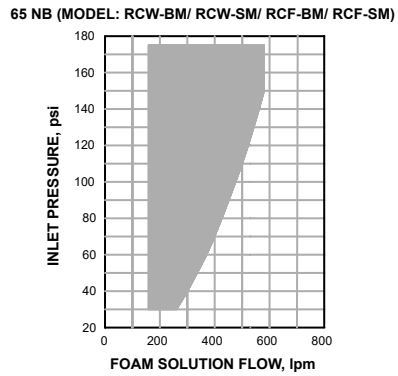
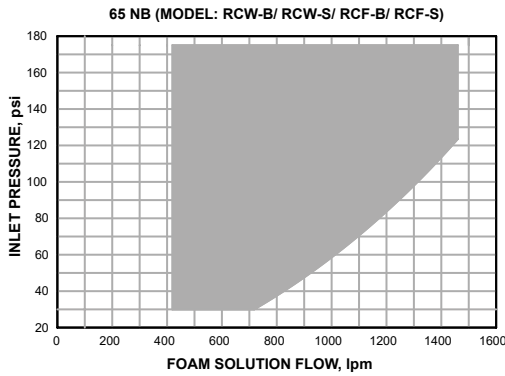

**INLET PRESSURE VS FOAM SOLUTION FLOW
FM APPROVED, MODEL RCW-B / RCW-S / RCF-B / RCF-S
(FOAM CONCENTRATE: AFFF 3%)**

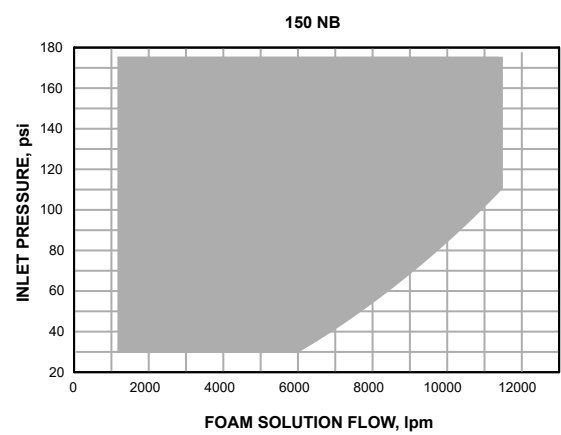
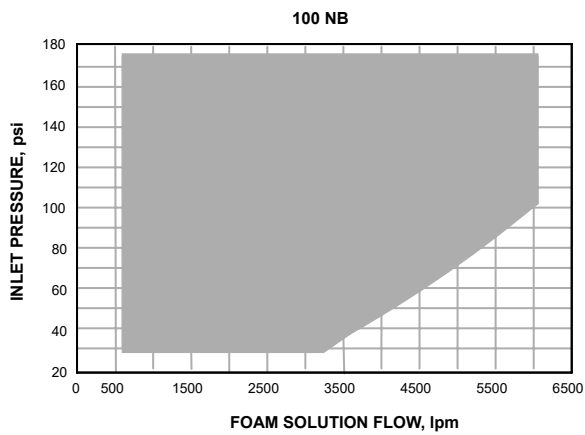
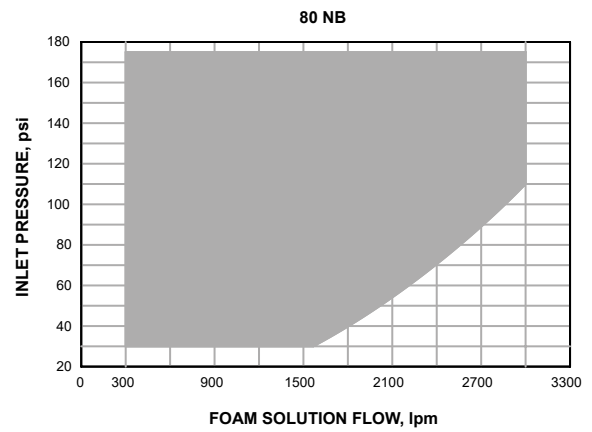
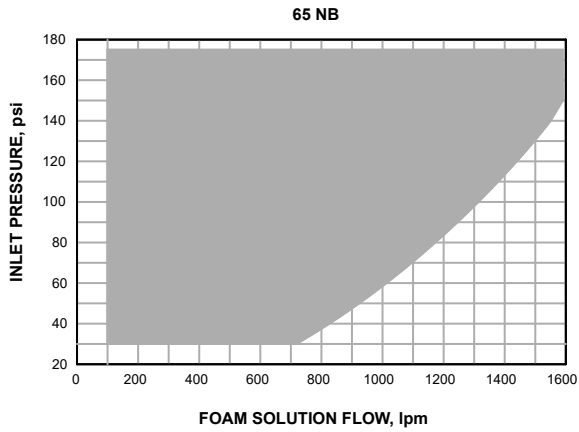

**INLET PRESSURE VS FOAM SOLUTION FLOW
FM APPROVED
(FOAM CONCENTRATE: AR-AFFF 3X3%)**

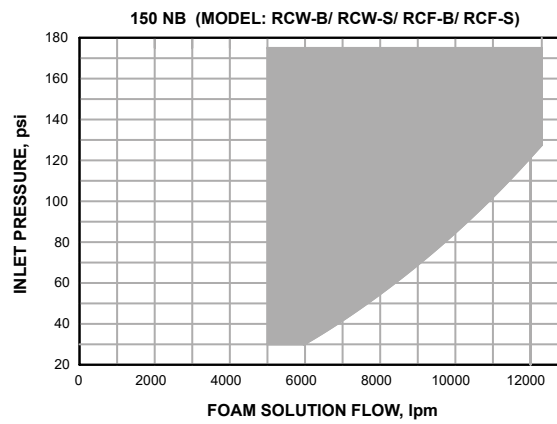
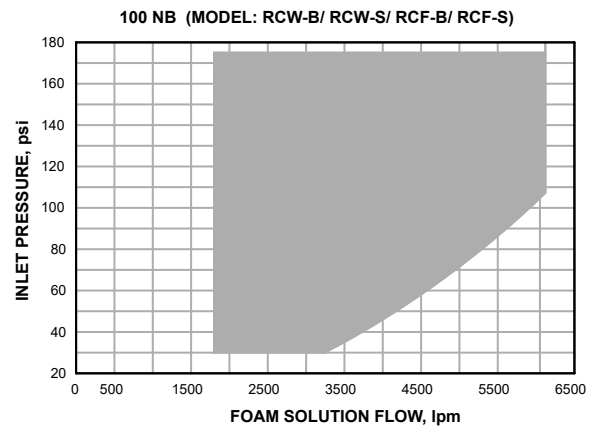
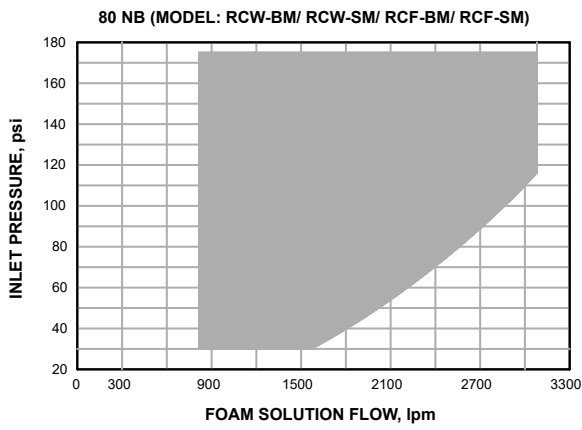
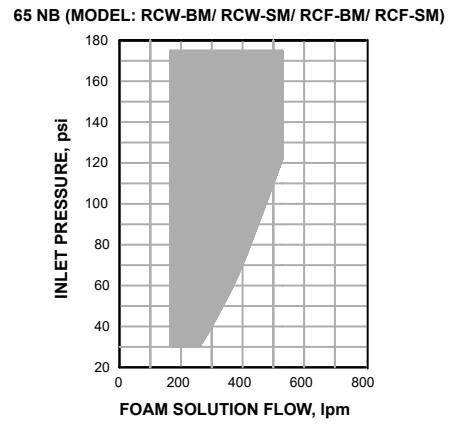
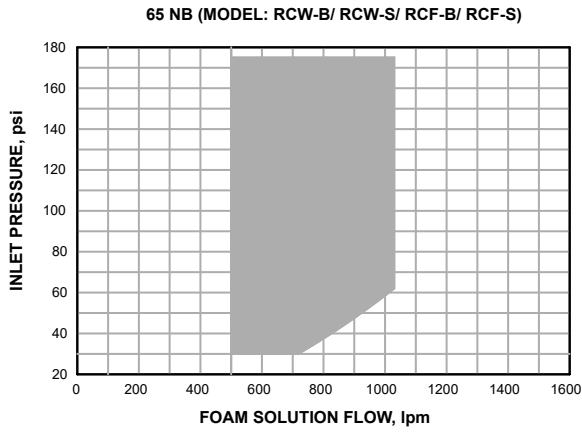

FLOW VS PRESSURE LOSS

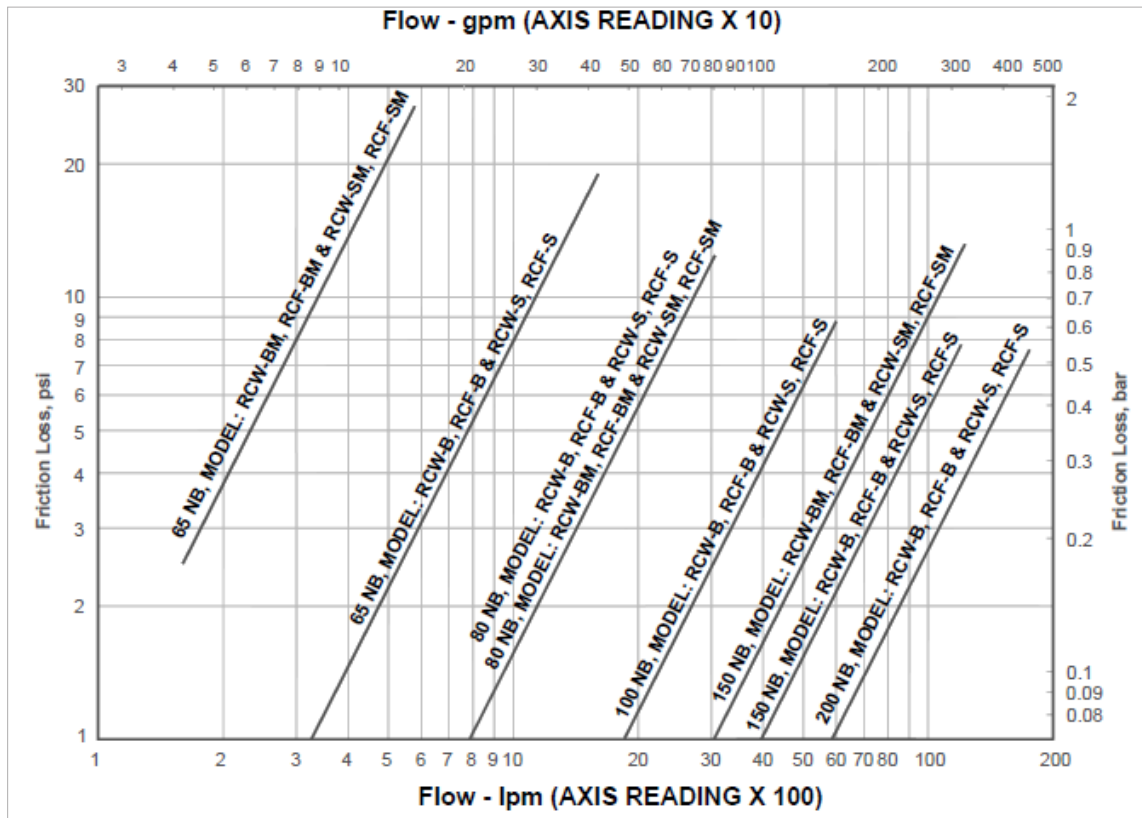

Note: Friction loss above 1 psi is plotted in the graph (flow range is as per given Table).

LIMITED WARRANTY

HD FIRE PROTECT PVT. LTD. hereby referred to as HD FIRE warrants to the original purchaser of the fire protection products manufactured by HD FIRE and to any other person to whom such equipment is transferred, that such products will be free from defect in material and workmanship under normal use and care, for two (2) years from the date of shipment by HD FIRE. Products or Components supplied or used by HD FIRE, but manufactured by others, are warranted only to the extent of the manufacturer's warranty. No warranty is given for product or components which have been subject to misuse, improper installation, corrosion, unauthorized repair, alteration or un-maintained. HD FIRE shall not be responsible for system design errors or improper installation or inaccurate or incomplete information supplied by buyer or buyer's representatives. HD FIRE will repair or replace defective material free of charge, which is returned to our factory, transportation charge prepaid, provided after our inspection the material is found to have been defective at the time of initial shipment from our works. HD FIRE shall not be liable for any incidental or consequential loss, damage or expense arising directly or indirectly from the use of the product including damages for injury to person, damages to property and penalties resulting from any products and components manufactured by HD FIRE. HD FIRE shall not be liable for any damages or labour charges or expense in making repair or adjustment to the product. HD FIRE shall not be liable for any damages or charges sustained in the adaptation or use of its engineering data & services. In no event shall HD Fire's product liability exceed an amount equal to the sale price. The foregoing warranty is exclusive and in lieu of all other warranties and representation whether expressed, implied, oral or written, including but not limited to, any implied warranties or merchantability or fitness for a particular purpose. All such other warranties and representations are hereby cancelled.

NOTICE :

The equipment presented in this bulletin is to be installed in accordance with the latest publication standards of NFPA or other similar organisations and also with the provision of government codes or ordinances wherever applicable.

The information provided by us is to the best of our knowledge and belief, and consist of general guidelines only. Site handling and installation control is not in our scope. Hence we give no guarantee for result and take no liability for damages, loss or penalties whatsoever, resulting from our suggestion, information, recommendation or damages due to our product.

Product development is a continuous programme of HD FIRE PROTECT PVT. LTD. and hence the right to modify any specification without prior notice is reserved with the company.



HD FIRE PROTECT PVT. LTD.
Protecting What Matters Most to You

D-6/2, ROAD NO. 34, WAGLE INDUSTRIAL ESTATE, THANE 400 604, INDIA.
 • TEL: + (91) 22 2158 2600 • FAX: +(91) 22 2158 2602
 • EMAIL: info@hdfire.com • WEB: www.hdfire.com