

SINGLE INTERLOCK, SUPERVISED PREACTION SYSTEM WITH DRY PILOT ACTUATION



TECHNICAL DATA

SIZE	50, 80, 100, 150 & 200 NB
DELUGE VALVE	Model H3, UL Listed
CHECK VALVE	Model-CH
SPRINKLER ALARM	UL Listed (Optional)
RELEASE PANEL	UL Listed (Optional)
WATER FLOW SWITCH	UL Listed
AUTOMATIC AIR SUPERVISOR	Oil-less Risermount Compressor (Optional)
AIR PRESSURE MAINTENANCE DEVICE	PMD-1 (Optional)
MANUAL SYSTEM SHUTOFF VALVE	UL Listed, Butterfly Valve - Standard supply. (Gate Valve - Optional)
MAXIMUM WORKING PRESSURE	17.5 Kg./sq.cm. (250 PSI)
SYSTEM END CONNECTION	Grooved (Standard supply) Flanged (Optional supply)
APPROVAL	UL Listed

DESCRIPTION

The Single Interlock Supervised Preaction System with Dry Pilot Actuation is generally used to protect water sensitive areas such as computer rooms, storage areas of valuable articles, to avoid water damage due to damaged sprinklers or damaged sprinkler piping. Preaction System is also effectively used to have Pre-alarm of a possible fire condition and allows time to extinguish fire by hand held fire extinguishing equipment, prior to water discharge through sprinkler heads. It uses an automatic sprinkler with supplemental detection system. In the event when fire cannot be extinguished by hand held fire extinguishing equipment, the increase in temperature will open one or more sprinkler heads to discharge water.

In normal condition, preaction system does not contain water in the sprinkler piping. The sprinkler piping contains air pressure for the purpose of supervising its leak tightness. As per NFPA, the preaction system employing more than 20 automatic sprinklers is to have the sprinkler piping automatically supervised.

The dry pilot system in single interlock preaction system will respond to a fire faster than the automatic sprinkler. The system designer selects the detection components for single interlock preaction system to detect the fire faster than automatic sprinkler.

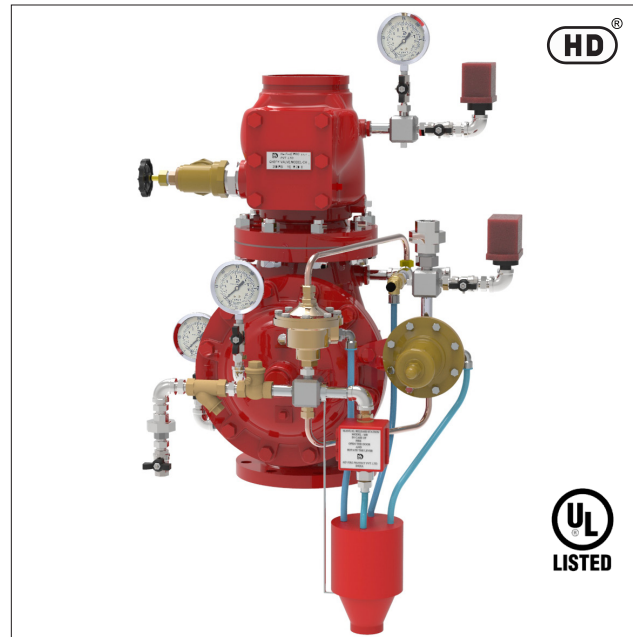

When fire is detected through dry pilot sprinkler system, the primary water control deluge valve opens, allowing water flow into the sprinkler piping in readiness for possible subsequent opening of one or more sprinklers.

SYSTEM OPERATION

The Single Interlock Supervised Preaction System with Dry Pilot Actuation utilizes automatic sprinklers and an additional pneumatic detection sprinkler system. When the pneumatic detection system sprinkler operates due to rise in temperature, the loss of air pressure will operate the pneumatic actuator of deluge valve and activate fire alarm devices. The sprinkler system also operates due to fire condition, then water flows through the sprinkler system.

The water flow will also produce water pressure in the alarm trim of deluge valve. This may actuate the pressure switch if additionally provided to control the shut down of equipment such as computers or start up of the second alarm devices. In normal condition the integrity of system is automatically supervised by the automatic air supervisory means. Air or nitrogen at 18 PSI (1.26 Bar) pressure is maintained in the sprinkler system up to the downstream of the riser check valve.

The supervisory low alarm switch is set at 6 PSI (0.42 Bar). The decreasing pressure will give trouble annunciation due to the loss of pressure, due to abnormal leakage in the sprinkler system piping as a result of the damaged sprinkler or broken pipeline. This will not open the deluge valve. The air pressure is for supervisory alarm only. The automatic supervisory air supply can be maintained through factory set air compressor.

Air or nitrogen at 42 PSI (2.94 Bar) is maintained in the dry pilot detection lines and a low pressure alarm switch provided in detection network is factory set at 20 PSI (1.40 Bar).

The compressor is compact and can be riser mounted or floor mounted. The supervisory air can be maintained with the tank mounted compressor and air maintenance device.

If continuous plant air supply or regulated Nitrogen source is available, then air maintenance device shall be used to maintain the supervisory air supply.

The major benefits of this system as compared to the conventional wet/dry sprinkler system are,

- a) A fire alarm sounds prior to operation of a sprinkler, which may enable to extinguishing of the fire by hand held means, before operation of any sprinkler head. This can eliminate water damage.
- b) Whenever integrity of the piping or sprinkler is disturbed, no water flows, only trouble annunciation alarm signals. This will avoid water damage to valuable property.
- c) Early fire alarm is provided by electric detection system, without the delay of water delivery time.

INSTALLATION & COMMISSIONING

The preaction system valves, panel, indicators must be installed in a readily visible and accessible location. The system valves and accessory shall not be installed in an area having temperature less than 4°C (40°F). Heat tracing to system valve and accessory is not permissible. The system must be installed and operated carefully by a trained person, having good knowledge of equipment. All system piping must be flushed thoroughly before commissioning.

After initial successful tests, an authorized person must be trained to perform inspection, testing and maintenance of the system.

RECOMMENDED SEQUENCE OF INSTALLATIONS

In planning the installation, consideration must also be given to the disposal of relatively large quantities of water that may be associated with draining of the system or performing flow test.

1. Install the Deluge Valve on Riser.
2. Install the Riser Check Valve above Deluge Valve as shown in installation drawing.
3. On completion of system piping, install all the trims as per trim drawing. Care must be taken to ensure that Check Valves, Strainers, Valves etc. are installed with the flow arrows in proper direction.
4. Connect all drain piping as shown in the drawing.

5. All unused opening on valve or trim parts must be plugged.
6. Connect air supply lines.
7. Connect all electrical to control panel as per wiring drawing.
8. Make sure that all the nut bolts, fittings are screwed properly.
9. Follow the valve resetting and test procedure.

RESETTING PROCEDURE

- a. Close the upstream side stop valve of the Deluge Valve.
- b. Open drain valves and allow water to drain (if water flow was establish) & close drain valve when water flow has ceased.
- c. Check all release devices are closed. Inspect the release devices if system was subject to fire condition.
- d. Open the air supply line to dry pilot actuator and check the pressure is maintained at 42 psi.
- e. Open the priming line so that the diaphragm chamber reads the system water pressure. Open the manual release station partly to vent the air & then close it.
- f. Open the upstream side of stop valve to read the Deluge Valve Inlet water supply pressure. The Deluge Valve is set.
- g. Open the supervisory air supply line and check the pressure is maintained up to 18 PSI (1.26 Bar) and Control Panel is kept on.
- i. Check all the trim parts for possible leak.

INSPECTION AND MAINTENANCE

Inspection and testing is to be carried out only by an authorized and trained personnel. DO NOT TURN OFF the water supply or close any valve to make repair(s) or test the valve, without placing a roving fire patrol in the area covered by the system. Also inform the local security personal and central alarm station, so that there is no false alarm signal. It is recommended to carry out physical inspection of the system at least twice a week. The inspection should verify that no damage has taken place to any components and check for following normal condition of the system.

NORMAL CONDITION

- a. All main valves are open and sealed with tamper proof seal.
- b. All drain valves are in closed condition.
- c. No leak or drip is detected from drip valve.

- d. All water gauge of deluge valve, should show the required pressure.
- e. No leak in any trim or other piping.
- f. Release panel is on and no abnormal indication are seen.
- g. All testing procedure to be verified at Jalgaon.

CAUTION

Procedure outlined below will result in operation of associated alarm. Concerned authorities to be informed about the tests before conducting the tests.

QUATERLY TEST

WATER FLOW ALARM TEST

Open the sprinkler alarm gong test valve, the water will flow through sprinkler alarm and/or water flow switch. On satisfactory observation close the alarm test valve.

AIR SUPPERVISORY LOW PRESSURE ALARM TEST

Release air pressure gradually through valve provided on check valve. When air pressure drops to 6 PSI (0.42 Bar), the supervisory low pressure alarm must be observed. Close the valve & observe that air pressure has been established to 18 PSI (1.26 Bar), the supervisory air pressure alarm must come to normal condition. If required reset the release panel.

ANNUAL OPERATION TEST

Testing valve operation without causing water apply to the deluge valve.

- a. Close the main system valve controlling water supply to the deluge valve.
- b. Open the main drain valve provided on deluge inlet side and allow water to drain. When water flow from drain valve has stopped crack open the main system valve and close the main drain valve partly allowing the water pressure at inlet of deluge valve to raise up to 1.4 Kg. / Sq. Cm.(20 PSI) and no more pressure is rising.
- c. Operate emergency release station; Deluge valve must open and water flow must be noticed through drip valve and the fire alarm bell should sound. Close the main supply control valve immediately and allow water to drain from drain valve.
- d. When water flow has stopped, reset the deluge valve as per resetting procedure.

CAUTION

The steps b & c must be performed very quickly to prevent water flow to riser.

NOTE: For abnormal condition of deluge valve refer the data sheet No. HD235.

CAUTION

The system must be inspected, tested and maintained as instructed above, in addition to the requirement of NFPA or as per requirement of authority having jurisdiction. The owner is responsible for the inspection, testing and maintenance of the system and devices.

**SINGLE INTERLOCK, SUPERVISED PREACTION SYSTEM WITH DRY PILOT ACTUATION
SCHEMATIC DIAGRAM**

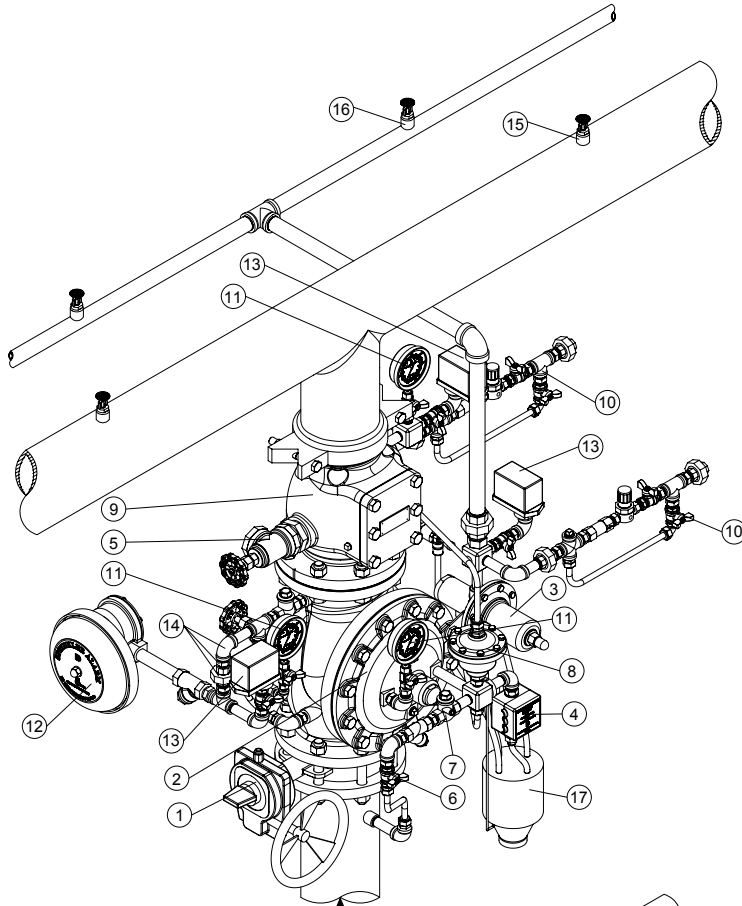

FRONT VIEW

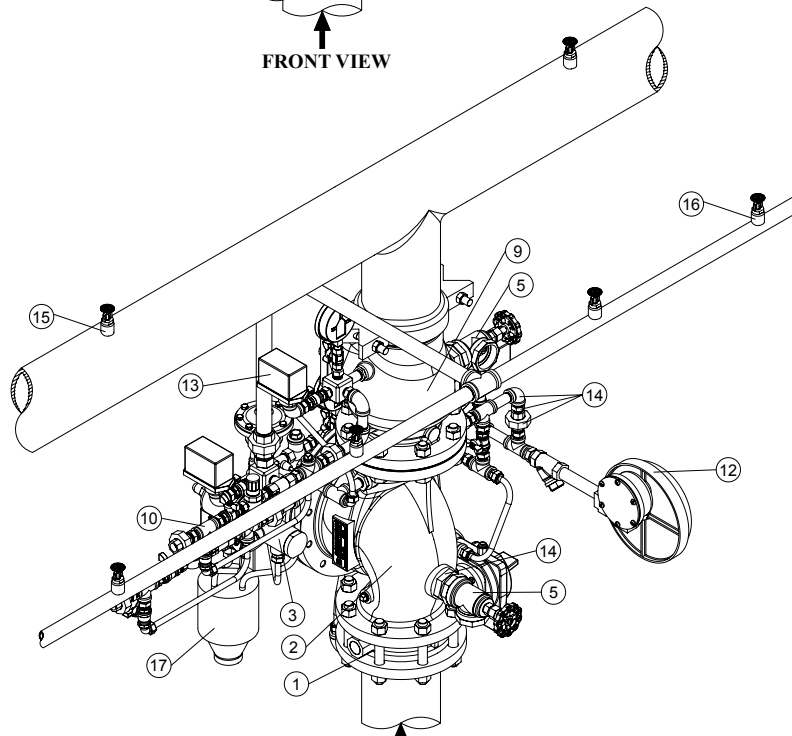

REAR VIEW

SINGLE INTERLOCK, SUPERVISED PREACTION SYSTEM WITH DRY PILOT ACTUATION PART LIST

ITEM NO	CODE NO	DESCRIPTION	PREACTION TRIM SIZE SIZE/ MAKE	QUANTITY PER PREACTION TRIM				
				200 NB	150 NB	100 NB	80 NB	50 NB
1		BFV WAFER TYPE GEAR OPRT. WITH TAMPER SWITCH *	2", HD MAKE (MODEL NO.HDMW300)	1	1	1	1	1
2	6458	DELUGE VALVE FLANGE END	2", HD MAKE (MODEL NO.DV-H3)	-	-	-	-	1
2	6455	DELUGE VALVE FLANGE END	3", HD MAKE (MODEL NO.DV-H3)	-	-	-	1	-
2	6454	DELUGE VALVE FLANGE END	4", HD MAKE (MODEL NO.DV-H3)	-	-	1	-	-
2	6453	DELUGE VALVE FLANGE END	6", HD MAKE (MODEL NO.DV-H3)	-	1	-	-	-
2	6457	DELUGE VALVE FLANGE END	8", HD MAKE (MODEL NO.DV-H3)	1	-	-	-	-
3	1563	DRY PILOT ACTUATOR	1/2" HD MAKE (MODEL NO. H1)	1	1	1	1	1
4	1951	EMERGENCY RELEASE STATION	1/2", HD MAKE (MODEL ERS-1)	1	1	1	1	1
5	9392	ANGLE VALVE	1-1/4"	-	-	-	2	2
5	9394	ANGLE VALVE	2"	2	2	2	-	-
6	9423	PRIMING VALVE	1/2"	1	1	1	1	1
7		RESTRICTED CHECK VALVE	1/2"	1	1	1	1	1
8	1825	ANTI RESET VALVE (ARV-1)	1/2"	1	1	1	1	1
9	3569	CHECK VALVE - FLANGE TO GROOVE	2", HD MAKE (MODEL NO. CH)	-	-	-	-	1
9	114345	CHECK VALVE - FLANGE TO GROOVE	3", HD MAKE (MODEL NO. CH)	-	-	-	1	-
9	114346	CHECK VALVE - FLANGE TO GROOVE	4", HD MAKE (MODEL NO. CH)	-	-	1	-	-
9	114343	CHECK VALVE - FLANGE TO GROOVE	6", HD MAKE (MODEL NO. CH)	-	1	-	-	-
9	114347	CHECK VALVE - FLANGE TO GROOVE	8", HD MAKE (MODEL NO. CH)	1	-	-	-	-
10	1674	PRESSURE MAINTENANCE DEVICE *	1/2" (PMD-1)	2	2	2	2	2
11	114071	PRESSURE GAUGE	0-300 PSI, UL LISTED	3	3	3	3	3
12	1416	SPRINKLER ALARM (GONG BELL) *	HD MAKE (TYPE-A)	1	1	1	1	1
13		PRESSURE SWITCH	POTTER MAKE, UL LISTED	3	3	3	3	3
14		TRIM FITTINGS		1	1	1	1	1
15		AUTOMATIC SPRINKLER **		-	-	-	-	-
16		DRY PILOT LINE SPRINKLER		-	-	-	-	-
17		SPLASH PROOF FUNNEL		1	1	1	1	1
* OPTIONAL SUPPLY								
** NOT SUPPLIED BY HD FIRE								
NOTES:								
DELUGE VALVE END CONNECTION (OPTIONAL - G X G/ F X F)						F = FLANGE END		
CHECK VALVE END CONNECTION (OPTIONAL - G X G/ F X G / F X F)						G = GROOVE END		
BUTTERFLY VALVE END CONNECTION (OPTIONAL - G X G/ WAFER TYPE / LUG TYPE)								
PRESSURE GAUGE (OPTIONAL - HDP-1 / HDP-2)								
OPTIONAL TRIM SUPPLY - LOOSE / SEMI ASSEMBLED)								
SHAPE OF FITTINGS / VALVES MAY CHANGE.								
SYSTEM PIPING, SPRINKLER, DETECTOR NOT SUPPLIED BY HD FIRE								
PRIMING LINE BY OTHERS								

ORDERING INFORMATION

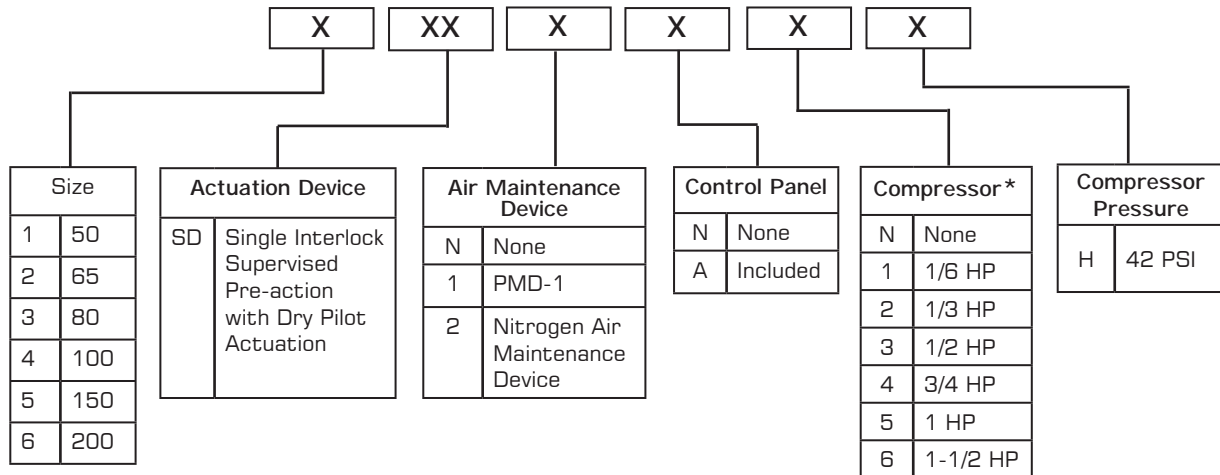

*Compressor standard supply is 50 Hz., 60 Hz is optional supply.

LIMITED WARRANTY

HD FIRE PROTECT PVT. LTD. hereby referred to as HD FIRE warrants to the original purchaser of the fire protection products manufactured by HD FIRE and to any other person to whom such equipment is transferred, that such products will be free from defect in material and workmanship under normal use and care, for two (2) years from the date of shipment by HD FIRE. Products or Components supplied or used by HD FIRE, but manufactured by others, are warranted only to the extent of the manufacturer's warranty. No warranty is given for product or components which have been subject to misuse, improper installation, corrosion, unauthorized repair, alteration or un-maintained. HD FIRE shall not be responsible for system design errors or improper installation or inaccurate or incomplete information supplied by buyer or buyer's representatives. HD FIRE will repair or replace defective material free of charge, which is returned to our factory, transportation charge prepaid, provided after our inspection the material is found to have been defective at the time of initial shipment from our works. HD FIRE shall not be liable for any incidental or consequential loss, damage or expense arising directly or indirectly from the use of the product including damages for injury to person, damages to property and penalties resulting from any products and components manufactured by HD FIRE. HD FIRE shall not be liable for any damages or labour charges or expense in making repair or adjustment to the product. HD FIRE shall not be liable for any damages or charges sustained in the adaptation or use of its engineering data & services. In no event shall HD Fire's product liability exceed an amount equal to the sale price. The foregoing warranty is exclusive and in lieu of all other warranties and representation whether expressed, implied, oral or written, including but not limited to, any implied warranties or merchantability or fitness for a particular purpose. All such other warranties and representations are hereby cancelled.

NOTICE :

The equipment presented in this bulletin is to be installed in accordance with the latest publication standards of NFPA or other similar organisations and also with the provision of government codes or ordinances wherever applicable.

The information provided by us is to the best of our knowledge and belief, and consist of general guidelines only. Site handling and installation control is not in our scope. Hence we give no guarantee for result and take no liability for damages, loss or penalties whatsoever, resulting from our suggestion, information, recommendation or damages due to our product.

Product development is a continuous programme of HD FIRE PROTECT PVT. LTD. and hence the right to modify any specification without prior notice is reserved with the company.



HD FIRE PROTECT PVT. LTD.
Protecting What Matters Most to You

D-6/2, ROAD NO. 34, WAGLE INDUSTRIAL ESTATE, THANE 400 604, INDIA.
 • TEL: + (91) 22 2158 2600 • FAX: +(91) 22 2158 2602
 • EMAIL: info@hdfire.com • WEB: www.hdfire.com