

# PRE-PACK<sup>®</sup> INTEGRATED PRE-ACTION SYSTEM



## TECHNICAL DATA

MODEL	Pre-Pack <sup>®</sup>
SIZE	50, 80, 100, 150 & 200 NB
DELUGE VALVE MODEL	DV-H3, UL Listed
RISER CHECK VALVE MODEL	CH
WATER MOTOR GONG BELL	UL Listed (Optional supply)
MAXIMUM WORKING PRESSURE	17.5 kg/sq.cm (250 psi)
SYSTEM END CONNECTION	Grooved - Standard supply Flanged - Optional supply
RELEASE PANEL	POTTER, UL Listed (Optional)
WATER FLOW SWITCH	POTTER, UL Listed
LOW PRESSURE ALARM SWITCH	POTTER, UL Listed
SOLENOID VALVE	Normally closed, 24 VDC. UL Listed
AUTOMATIC AIR SUPPLY	Oil Less Riser Mounted Compressor (Optional)
MANUAL SYSTEM SHUT OFF VALVE	Butterfly Valve, UL Listed (With Tamper Switch)
TYPE	Single Interlock - Wet Pilot Single Interlock - Dry Pilot Single Interlock - Electric Double Interlock- Electric/ Pneumatic Double Interlock- Electric/Electric
CABINET	14 SWG, Red Finish (RAL 3001)
APPROVAL	UL Listed

## DESCRIPTION

HD Pre-Pack<sup>®</sup> is a pre-assembled Pre-Action System enclosed in cabinet. Pre-action systems are designed for water sensitive areas that require protection from inadvertent water flow into the sprinkler system piping. HD Pre-Pack<sup>®</sup> system comes with grooved ends to provide minimum installation time. It comes in a compact, space saving, self-standing cabinet while providing an aesthetically pleasing appearance.

## FEATURES

- Professionally pre-assembled and factory tested
- Internally wired
- Quick and convenient installation
- Compact, space saving and aesthetically pleasing appearance
- Custom manufactured
- UL Listed



## CONSTRUCTION

Pre-Pack<sup>®</sup> is a pre-assembled Pre-Action System enclosed in free standing cabinet. The cabinet is pre-wired and requires water inlet, outlet valve riser and drain. All connections are grooved-type to provide minimal installation time.

Pre-Pack<sup>®</sup> includes Deluge Valve, Riser Check Valve, Water Supply Stop Valve, Water Flow Supervisory Switch, Pressure Gauges, Built-in Air Compressor and Control Panel with battery backup. The cabinet comes with windows for viewing the release panel function and pressure gauges.

The cabinet is constructed of 14 gauge steel and standard finish is red. The front door is hinged and removable. All four sides of the cabinet can be removed for ease of maintenance. Cabinet base plate comes with pre-drilled holes, which provide an anchor point for the cabinet for securing to the floor. All internal valves and major components are individually tagged for identification.

The water motor gong bell is supplied pre-assembled with inlet & drain connection to the left side of the cabinet. If required, the water motor gong bell can be supplied loose and a connection is provided for field installation.

A hard piped funnel drain is connected through swing check valve to the main drain line. The funnel is provided with splash proof cap so that water does not splash into the cabinet during flow. It is fail-safe feature allowing water to overflow in the event the drain is blocked. A cable entry is provided at bottom of the cabinet.

Pre-Pack<sup>®</sup> is also available without Releasing/ Control Panel and Air Compressor.

Optionally a Nitrogen Generator System can be connected to HD Pre-Pack<sup>®</sup> System.

## OPERATION

System comprises mainly of two configurations:

### 1. Double Interlock

Double Interlock configuration is more commonly used in industry and it comes with two options:

1. Electric/Pneumatic and
2. Electric/Electric.

Both these options have been specified in individual datasheets: HD 128 and HD 127

### 2. Single Interlock

Single Interlock configuration comes in three options:

1. Wet Pilot
2. Dry Pilot
3. Electric

All these options have been specified in individual datasheets: HD 126, HD 125 and HD 124

### Double Interlock Pre-Action System with Electric/Pneumatic Actuation:

This is most commonly used system. This system utilizes a Deluge Valve Model H3 and Riser Check Valve Model CH. The Riser Check Valve isolates the Deluge Valve from the system air pressure. Riser Check Valve provides an air check, so that the system can be automatically pressurized with a supervisory air or nitrogen pressure of 42 psi (2.94 bar). A supervisory low pressure alarm switch can be set at 20 psi (1.40 bar), on decreasing pressure, to indicate whether there are any abnormal leaks in the sprinkler system piping. Loss of air pressure from the system due to accidental leakage will not cause Deluge Valve to open.

The releasing trim for Deluge Valve utilizes a Solenoid Valve and a Dry Pilot Actuator in a series configuration. The system air pressure holds the Dry Pilot Actuator closed, whereas the Solenoid Valve remains closed until it is electrically energized by a Deluge Valve Releasing Panel (automatic control unit). The Releasing Panel is operated by either a fire detection device or manual electric pull station. In order for the Double Interlock Pre-Action System to automatically actuate, two independent events must occur. The Deluge Valve Releasing Panel must operate and open the Solenoid Valve upon automatic operation of the electric fire detection initiating circuit and the sprinkler system piping must lose air pressure due to operation of one or more sprinklers. The Double Interlock Pre-Action System will automatically actuate only when both the Dry Pilot Actuator and the Solenoid Valve are open at the same time. Unintended opening of just the Dry Pilot Actuator or the Solenoid Valve will only cause an alarm and not actuate the system or flood the sprinkler system piping.

### Double Interlock Pre-Action System with Electric/Electric Actuation

This system utilizes a Deluge Valve Model H3 and Riser Check Valve Model CH. The Riser Check Valve isolates the Deluge Valve from the system air pressure. Riser Check Valve provides an air check so that the system can be automatically pressurized with a supervisory air or nitrogen pressure of 18 psi (1.26 bar). A supervisory low pressure alarm switch can be set at 6 psi (0.42 bar), on decreasing pressure, to indicate whether there are any abnormal leaks in the sprinkler system piping. Loss of air pressure from the system due to accidental leakage will not cause Deluge Valve to open.

The releasing trim for the Deluge Valve utilizes a Solenoid Valve that is energized with cross-zone releasing circuit of release panel.

The Solenoid Valve remains closed until it is electrically energized by a Deluge Valve Releasing Panel (automatic control unit). The Releasing Panel is operated by either a fire detection device or manual electric pull station. In order for the Double Interlock Pre-Action System to automatically actuate, two independent events must occur. Zone 1 of the Releasing Panel must operate upon automatic operation of the electric fire detection initiating circuit or operation of the electric-manual pull initiating circuit, and Zone 2 of the Releasing Panel must operate via the Low Air Pressure Alarm Switch upon loss of air pressure from the sprinkler system piping, due to operation of one or more sprinklers. The Double Interlock Pre-Action System will automatically actuate only when both Zone 1 and Zone 2 of the Releasing Panel have operated, energizing the Solenoid Valve.

### Single Interlock Pre-Action System with Wet Pilot Actuation

This system utilizes a Deluge Valve Model H3 and Riser Check Valve Model CH. The Riser Check Valve isolates the Deluge Valve from the system air pressure. Riser Check Valve provides an air check so that the system can be automatically pressurized with a supervisory air or nitrogen pressure of 18 psi (1.26 bar). A supervisory low pressure alarm switch can be set at 6 psi (0.42 bar), on decreasing pressure, to indicate whether there are any abnormal leaks in the sprinkler system piping. Loss of air pressure from the system due to accidental leakage will not cause Deluge Valve to open.

System actuation is carried out by Wet Pilot Line, consisting of Wet Pilot Sprinklers for detection. Actuation of Wet Pilot Line releases Deluge Valve, which allows water to flow into sprinkler line.

### Single Interlock Pre-Action System with Dry Pilot Actuation

This system utilizes a Deluge Valve Model H3 and Riser Check Valve Model CH. The Riser Check Valve isolates the Deluge Valve from the system air pressure. Riser Check Valve provides an air check so that the system can be automatically pressurized with a supervisory air or nitrogen pressure of 18 psi (1.26 bar). A supervisory low pressure alarm switch can be set at 6 psi (0.42 bar), on decreasing pressure, to indicate whether there are any abnormal leaks in the sprinkler system piping. Loss of air pressure from the system due to accidental leakage will not cause Deluge Valve to open.

System actuation is carried out by Dry Pilot Actuator, consisting of Dry Pilot Sprinklers for detection. Actuation of Dry Pilot Actuator releases Deluge Valve, which allows water to flow into sprinkler line. The Dry Pilot Sprinkler line to be pressurized with 42 psi (2.94 bar) air pressure.

Two independent Pressure Maintenance Devices are to be utilized for maintaining the supervisory air pressure and Dry Pilot line pressure.

### Single Interlock Pre-Action System with Electric Actuation

This system utilizes a Deluge Valve Model H3 and Riser Check Valve Model CH. The Riser Check Valve isolates the Deluge Valve from the system air pressure. Riser Check Valve provides an air check so that the system can be automatically pressurized with a supervisory air or nitrogen pressure of 18 psi (1.26 bar). A supervisory low pressure alarm switch can be set at 6 psi (0.42 bar), on decreasing pressure, to indicate whether there are any abnormal leaks in the sprinkler system piping. Loss of air pressure from the system due to accidental leakage will not cause Deluge Valve to open.

System actuation is carried out by supplemental detection system, which typically comprises of 24 VDC heat detectors, smoke detectors, manual pull stations, etc. Actuation of the detection system automatically operates the Deluge Valve, allowing water to flow into the sprinkler piping system, to be discharged from any sprinklers that are open.

### INSTALLATION REQUIREMENT

The Pre-Pack<sup>®</sup> Cabinet and all interconnecting piping must be located indoors in a readily visible and accessible location and in an area having minimum temperature of 4°C (40°F). **Heat tracing is not permitted.** The automatic sprinklers, releasing devices, fire detection devices, must be UL Listed.

Two separate power supply connections to be provided to compressor and electric panel. Two separate terminal sets are provided in the Pre-Pack<sup>®</sup> system.

Electric panel is to be powered by 230V AC, 50 Hz stabilized power supply (with surge protection).

The compressor power requirement is single phase 230V AC, 50 Hz (may vary in different countries) stabilized power supply (with surge protection).

### CAUTION

- The electric power supply shall be stabilized power supply (with surge protection, preferably through UPS)
- Never weld or modify any piping.
- Follow the instructions provided on packed Pre-Pack<sup>®</sup> for opening the wooden box.

### SYSTEM AIR/NITROGEN PRESSURE REQUIREMENT

A suitable sized water supply to the water supply header, common drain piping, system piping including automatic sprinkler/ nozzles and a detection system piping need to be installed connecting to Pre-Pack<sup>®</sup>.

If the Supervisory Compressor is not taken with Pre-Pack<sup>®</sup>, then a suitable compressor/ plant air supply/ N<sub>2</sub> connection to be provided with Air Maintenance Device. The selection of compressor shall depend on volume of detection line.

### HYDROTESTING

As required by NFPA13, Fire Sprinkler System must be hydrotested and pressure need to be maintained without loss, for two hours. The test pressure shall be as per NFPA 13. In addition to the hydrostatic testing, dry pipe and double interlock pre-action system requires an additional low pressure air test.

### INSPECTION AND MAINTENANCE

Inspection and testing is to be carried out only by authorized and trained personnel. DO NOT TURN OFF the water supply or close any valve to make repair(s) or test the valve, without placing a roving fire patrol in the area covered by the system. Also inform the local security personal and central alarm station, so that there is no false alarm signal. It is recommended to carry out physical inspection of the system at least twice a week. The inspection should verify that no damage has taken place to any components and check for following normal condition of the system.

Inspection, Testing and Maintenance must be performed in accordance with NFPA and or authority having jurisdiction.

#### NOTE:

The Pressure Gauges standard supply is 300 psi for water gauge for system pressure upto 175 psi. If system pressure is more than 175 psi, then order for 600 psi water pressure gauges.

## TYPICAL PRE-PACK<sup>®</sup> ASSEMBLY ARRANGEMENT SYSTEM WITH COMPRESSOR AND RELEASING PANEL

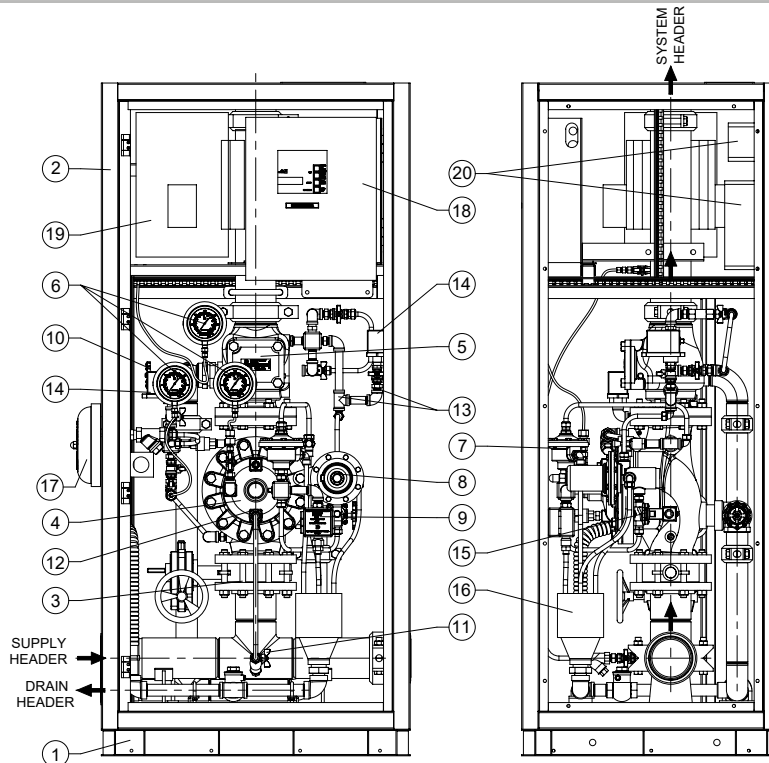

## TYPICAL PRE-PACK<sup>®</sup> ASSEMBLY ARRANGEMENT SYSTEM WITHOUT COMPRESSOR AND RELEASING PANEL

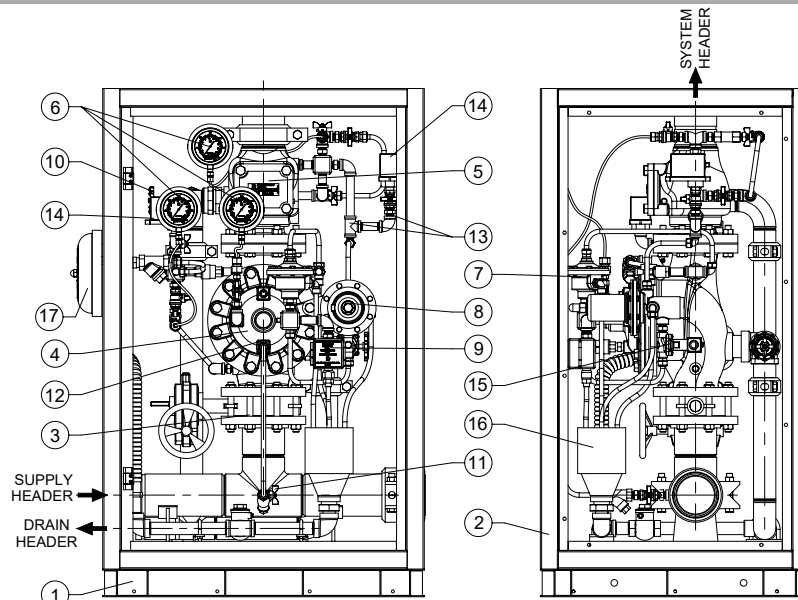

1	BASE FRAME	8	DRY PILOT ACTUATOR	15	SOLENOID VALVE
2	CABINET	9	EMERGENCY RELEASE STATION	16	SPLASH PROOF FUNNEL
3	BUTTERFLY VALVE WITH TAMPER SWITCH	10	ANGLE VALVE	17	SPRINKLER ALARM
4	DELUGE VALVE	11	PRIMING VALVE	18	RELEASE PANEL
5	CHECK VALVE	12	RESTRICTED CHECK VALVE	19	AIR COMPRESSOR
6	PRESSURE GAUGE	13	TRIM FITTINGS	20	JUNCTION BOX
7	ANTI RESET VALVE	14	PRESSURE SWITCH		

## FRICITION LOSS

Friction loss expressed in equivalent length of Schedule 40 pipe and based on Hazen-Williams Formula with C=120 and a flowing velocity of 4.6 mtrs. (15 ft/sec) is as under. The friction loss is with Deluge Valve, Check Valve, Supply Manifold and System Shut-off Valve.

Valve Size	Equivalent Length in metres
50 mm (2")	8.0
80 mm (3")	17.5
100 mm (4")	20.0
150 mm (6")	46.2
200 mm (8")	72.0

## GROOVED END DIMENSIONS

Valve Size	Outer Diameter	Groove Diameter	Groove Width	Outlet face to Groove
50mm (2")	60mm (2.357")	57mm (2.250")	8mm (5/16")	16mm (5/8")
80mm (3")	89mm (3.5")	85mm (3.344")	8mm (5/16")	16mm (5/8")
100mm (4")	114mm (4.5")	110mm (4.334")	10mm (3/8")	16mm (5/8")
150mm (6")	165mm (6.496")*	161mm (6.385")	10mm (3/8")	16mm (5/8")
200mm (8")	219mm (8.625")	214mm (8.441")	11mm (7/16")	19mm (3/4")

\*Pipe diameter 168(6.625") is optional.

## PRINCIPAL COMPONENT

	Description	Make	Approval	Data Sheet No
1.	Deluge Valve	HD Fire	UL Listed	HD 235
2.	Check Valve	HD Fire	UL Listed with Pre-action system	HD 104
3.	Single Interlock, Electric Actuation	HD Fire	UL Listed	HD 124
4.	Single Interlock, Dry Pilot Actuation	HD Fire	UL Listed	HD 125
5.	Single Interlock, Wet Pilot Actuation	HD Fire	UL Listed	HD 126
6.	Double Interlock, Electric /Pneumatic Actuation	HD Fire	UL Listed	HD 128
7.	Double Interlock, Electric /Electric Actuation	HD Fire	UL Listed	HD 127
8.	Release Panel	Potter	UL Listed	# **
9.	Pressure Alarm Switch	Potter	UL Listed	#
10.	Pressure Alarm Switch	Potter	UL Listed	#
11.	Butterfly Valve (System Shutoff Valve)	HD Fire	UL Listed	HD 282
12.	Automatic Supervisory Air Supply (Compressor)	General Air Products	CE or UL Listed	--
13.	Air Pressure Maintenance Device	HD Fire	UL Listed with Pre-action System	HD 129
14.	Nitrogen Maintenance Device	HD Fire	--	--

# Refer [www.pottersignal.com](http://www.pottersignal.com)

\*\* PFC-4410RC

### NOTE:

Battery of 12V-14 Ah is standard supply in separate packing, it needs to be mounted in panel while installing the Pre-Pack®. Higher capacity battery is optional supply.

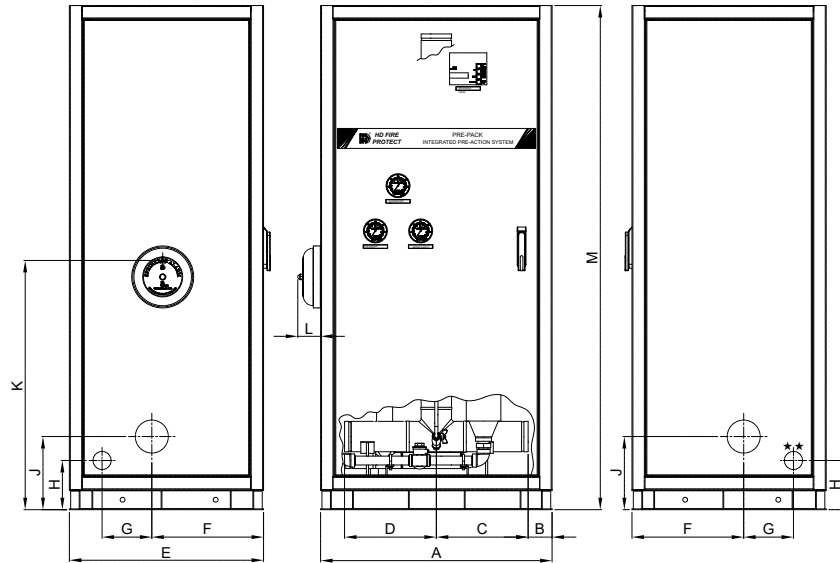
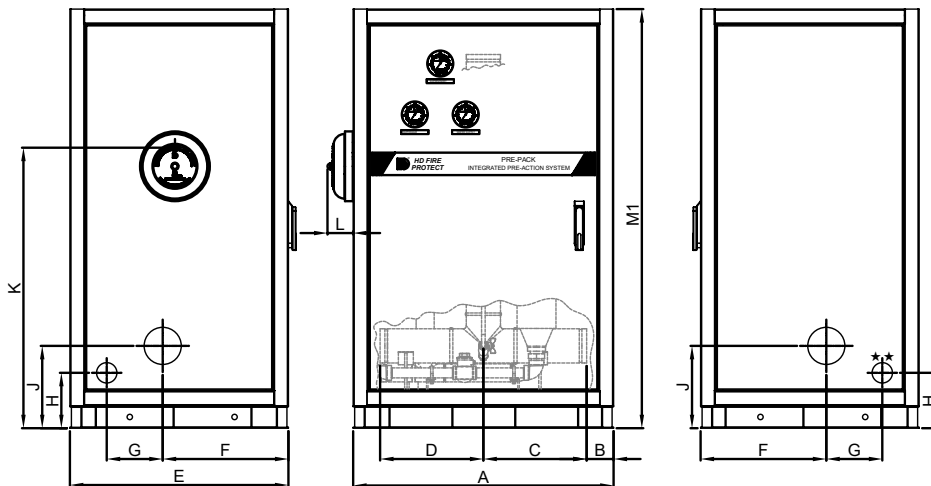
**PRE-ACTION CABINET OVERALL DIMENSIONS (WITH COMPRESSOR & RELEASING PANEL)**

**PRE-ACTION CABINET OVERALL DIMENSIONS (WITHOUT COMPRESSOR & RELEASING PANEL)**

**DIMENSIONS**

SIZE	A	B	C	D	E	F	G	H	J	K	L	M	M1
50 NB	800	152	248	248	690	407.5	171	185	275	800.5	86	1785	1325
80 NB	800	152	248	248	690	407.5	171	185	275	800.5	86	1785	1325
100 NB	870	90	345	345	730	420	187	185	275	937	86	1895	1400
150 NB	930	80	385	385	750	420	215	190	315	1061	86	2035	1540
200 NB	930	80	385	385	850	476	259	190	340	1170	86	2275	1770

**NOTE:**

- Cabinet material Carbon steel Painted RAL 3001 (SS Optional)
- Dimensions of Cabinet may change as per client's requirement
- \*\*Optional Drain opening on right side of Cabinet
- Dimensions are approximate
- All dimensions are in mm

**OPTIONAL SUPPLY:**

- (i) A lock for cabinet.
- (ii) Water Motor Gong Bell is optional supply, Pre-mounted or loose supply for field connection.
- (iii) Air Maintenance Device or Nitrogen Maintenance Device.
- (iv) Pre-mounted Water Motor Gong Bell can be supplied on left side of Cabinet only.

### PRE-PACK<sup>®</sup> SYSTEM AIR (NITROGEN) PRESSURE

Pre-Action System Type		Compressor *		Factory set low Pressure Alarm
		ON	OFF	
Single Interlock Electric		13 psi	18 psi	6 psi (±1 psi)
Single Interlock Wet Pilot		13 psi	18 psi	6 psi (±1 psi)
Single Interlock Dry Pilot	Supervisory	13 psi	18 psi	6 psi (±1 psi)
	Dry Pilot	28 psi	42 psi	20 psi (±1 psi)
Double Interlock Electric/ Electric		13 psi	18 psi	6 psi (±2 psi)
Double Interlock Electric/ Pneumatic		28 psi	42 psi	20 psi (±2 psi)

\*Compressor is factory set for ON and OFF, ± 2 psi for low pressure compressor and ± 3 psi for high pressure compressor.

### AIR COMPRESSOR SELECTION FOR PRE-PACK<sup>®</sup> SYSTEM

System Capacity	Model No.	Power Supply (KW)	Electric Pneumatic Actuation	Electric - Electric Actuation
			System Volume in litres for 40 psi in 30 minutes	System Volume in litres for 18 psi in 30 minutes
1048 L	OL39012AC-LP-50	0.12	--	1048
1762 L	OL75025AC-LP-50	0.25	--	1762
2874 L	OL114056AC-LP-50	0.56	--	2874
3743 L	OL135075AC-LP-50	0.75	--	3743
390 L	OL39012AC-50	0.12	390	--
750 L	OL75025AC-50	0.25	750	--
1140 L	OL114056AC-50	0.56	1140	--
1350 L	OL135075AC-50	0.75	1350	--
1965 L	OL1965120AC-50	1.20	1965	--
2870 L	OL2870150AC-50	1.50	2870	--

**Note:**

- Standard supply is 115V, AC, 50 Hz provided.
- Optional supply if specified in order, then 115V, AC, 60 Hz can be supplied.
- For higher capacity, contact marketing.
- Compressors are from General Air Products and are oil less riser mounted.
- System capacity based on 21°C system temperature.

**PRE-PACK® SYSTEM ORDERING INFORMATION**

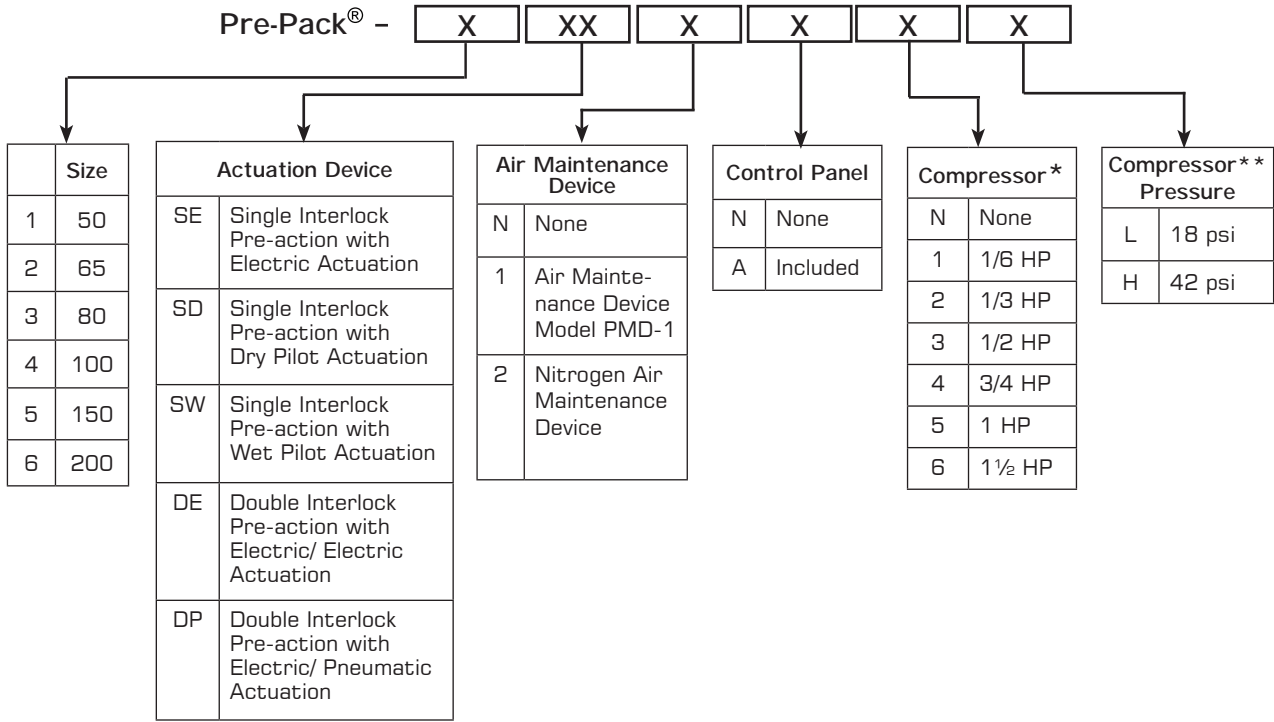

\*Compressor standard supply is 50 Hz., 60 Hz is optional supply.  
Installer to specify the compressor capacity required depending on pipeline volume.

\*\*For Pneumatic or Dry Pilot Actuation, Compressor Pressure has to be 42 psi (H).

**LIMITED WARRANTY**

HD FIRE PROTECT PVT. LTD. hereby referred to as HD FIRE warrants to the original purchaser of the fire protection products manufactured by HD FIRE and to any other person to whom such equipment is transferred, that such products will be free from defect in material and workmanship under normal use and care, for two (2) years from the date of shipment by HD FIRE. Products or Components supplied or used by HD FIRE, but manufactured by others, are warranted only to the extent of the manufacturer's warranty. No warranty is given for product or components which have been subject to misuse, improper installation, corrosion, unauthorized repair, alteration or un-maintained. HD FIRE shall not be responsible for system design errors or improper installation or inaccurate or incomplete information supplied by buyer or buyer's representatives. HD FIRE will repair or replace defective material free of charge, which is returned to our factory, transportation charge prepaid, provided after our inspection the material is found to have been defective at the time of initial shipment from our works. HD FIRE shall not be liable for any incidental or consequential loss, damage or expense arising directly or indirectly from the use of the product including damages for injury to person, damages to property and penalties resulting from any products and components manufactured by HD FIRE. HD FIRE shall not be liable for any damages or labour charges or expense in making repair or adjustment to the product. HD FIRE shall not be liable for any damages or charges sustained in the adaptation or use of its engineering data & services. In no event shall HD Fire's product liability exceed an amount equal to the sale price. The foregoing warranty is exclusive and in lieu of all other warranties and representation whether expressed, implied, oral or written, including but not limited to, any implied warranties or merchantability or fitness for a particular purpose. All such other warranties and representations are hereby cancelled.

**NOTICE :**

The equipment presented in this bulletin is to be installed in accordance with the latest publication standards of NFPA or other similar organisations and also with the provision of government codes or ordinances wherever applicable.

The information provided by us is to the best of our knowledge and belief, and consist of general guidelines only. Site handling and installation control is not in our scope. Hence we give no guarantee for result and take no liability for damages, loss or penalties whatsoever, resulting from our suggestion, information, recommendation or damages due to our product.

Product development is a continuous programme of HD FIRE PROTECT PVT. LTD. and hence the right to modify any specification without prior notice is reserved with the company.

