

DOUBLE INTERLOCK, PREACTION SYSTEM WITH ELECTRIC/ELECTRIC RELEASE



TECHNICAL DATA

SIZE	50, 80, 100, 150 & 200 NB
DELUGE VALVE	Model H3, UL Listed
CHECK VALVE	Model-CH
SPRINKLER ALARM	UL Listed (Optional)
RELEASE PANEL	UL Listed (Optional)
WATER FLOW SWITCH	UL Listed
SOLENOID VALVE	24V DC, UL Listed
AUTOMATIC AIR SUPERVISOR	Oil-less Risermount Compressor (Optional)
AIR PRESSURE MAINTENANCE DEVICE	PMD-1 (Optional)
MANUAL SYSTEM SHUTOFF VALVE	UL Listed, Butterfly Valve - Standard supply. (Gate Valve - Optional)
MAXIMUM WORKING PRESSURE	17.5 Kg./sq.cm. (250 PSI)
SYSTEM END CONNECTION	Grooved (Standard supply) Flanged (Optional supply)
APPROVAL	UL Listed

DESCRIPTION

The Double Interlock Preaction System with Electric/Electric Release is generally used to protect water sensitive areas such as computer rooms, storage areas, refrigerated areas etc., to avoid water damage due to inadvertent flooding of the sprinkler system piping.

In normal condition, preaction system does not contain water in the sprinkler piping. The sprinkler piping contains air pressure for the purpose of supervising its leak tightness.

This system utilizes a Deluge Valve H3 and Riser Check Valve model CH. The Riser Check Valve isolates the Deluge Valve from the system air pressure. Riser Check Valve provides an air check so that the system can be automatically pressurized with a supervisory air or nitrogen pressure of 18 PSI (1.26 Bar). A supervisory low pressure alarm switch can be set at 6 PSI (0.42 Bar), on decreasing pressure, to indicate whether there are any abnormal leaks in the sprinkler system piping. Loss of air pressure from the system due to accidental leakage will not cause Deluge Valve to open.

The releasing trim for Deluge Valve utilizes a Solenoid Valve that is energized with cross-zone releasing circuit of release panel.



The Releasing Panel is operated by either a fire detection device or manual electric pull station. In order for the Double Interlock Pre-action System to automatically actuate, two independent events must occur: Zone 1 of the Releasing Panel must operate upon automatic operation of the electric fire detection initiating circuit or operation of the electric-manual pull initiating circuit, and Zone 2 of the Releasing Panel must operate via the Low Air Pressure Alarm Switch upon loss of air pressure from the sprinkler system piping, due to operation of one or more sprinklers. The Double Interlock Preaction System will automatically actuate only when both Zone 1 and Zone 2 of the Releasing Panel have operated, energizing the Solenoid Valve.

Deluge Valve H3 is diaphragm valve as described in Technical Data Sheet HD 235.

INSTALLATION & COMMISSIONING

The preaction system valves, panel, indicators must be installed in a readily visible and accessible location. The system valves and accessory shall not be installed in an area having temperature less than 4°C (40°F). Heat tracing to system valve and accessory is not permissible. The system must be installed and operated carefully by a trained person, having good knowledge of equipment. All system piping must be flushed thoroughly before commissioning.

After initial successful tests, an authorized person must be trained to perform inspection, testing and maintenance of the system.

RECOMMENDED SEQUENCE OF INSTALLATIONS

In planning the installation, consideration must also be given to the disposal of relatively large quantities of water that may be associated with draining of the system or performing flow test.

1. Install the Deluge Valve on Riser in vertical position.
2. Install the Riser Check Valve above Deluge Valve as shown in installation drawing.
3. On completion of system piping, install all the trims as per trim drawing. Care must be taken to ensure that Check Valves, Strainers, Valves etc. are installed with the flow arrows in the proper direction.
4. Connect all drain piping as shown in the drawing.
5. All unused opening on valve or trim parts must be plugged.
6. Connect air supply line.
7. Connect all electrical to control panel as per wiring drawing.
8. Make sure that all the nut bolts, fittings are screwed properly.
9. Follow the valve resetting and test procedure.
10. The pipe fittings and nipple must be cleaned. Use thread sealant on male threads only.
11. For common drain piping a check valve to be provided interconnecting main drain and the funnel.
12. The drain tubing to be drip funnel must be installed with smooth bends that will restrict flow.
13. The drain piping must be free-flow and care must be taken to direct the drain in proper area to avoid damage due to release of system.
14. A supervisory air or nitrogen supply is to be installed as given in the data sheet. An air dryer, if specified, needs to be installed as per authority having jurisdiction.
15. The electric connection through conduit is to be made as per authority having jurisdiction.

RESETTING PROCEDURE

- a. Close the upstream side stop valve of the Deluge Valve.
- b. Open drain valves and allow water to drain (if water flow was established) & close drain valve when water flow has ceased.
- c. Check all release devices are closed. Inspect the release devices if system was subject to fire condition.

- d. Open the priming line so that the diaphragm chamber reads the system water pressure. Open the manual release station partly to vent the air & then close it.
- e. Open the upstream side of stop valve to read the Deluge Valve Inlet water supply pressure. The Deluge Valve is set.
- f. Open the air supply line and check the pressure is maintained up to 18 PSI (1.26 Bar) and Control Panel is kept on.
- h. Check all the trim parts for possible leak.

INSPECTION AND MAINTENANCE

Inspection and testing is to be carried out only by an authorized and trained personnel. DO NOT TURN OFF the water supply or close any valve to make repair(s) or test the valve, without placing a roving fire patrol in the area covered by the system. Also inform the local security personal and central alarm station, so that there is no false alarm signal. It is recommended to carry out physical inspection of the system at least twice a week. The inspection should verify that no damage has taken place to any components and check for following normal condition of the system. The owner is responsible for maintaining the pre-action system.

NORMAL CONDITION

- a. All main valves are open and sealed with tamper proof seal.
- b. All drain valves are in closed condition.
- c. No leak or drip is detected from drip valve.
- d. All water gauge of deluge valve, should show the required pressure.
- e. No leak in any trim or other piping.
- f. Release panel is on and no abnormal indication are seen.
- g. All testing procedure to be verified.

CAUTION

Procedure outlined below will result in operation of associated alarm. Concerned authorities to be informed about the tests before conducting the tests.

QUARTERLY TEST WATER FLOW ALARM TEST

Open the sprinkler alarm gong test valve, the water will flow through sprinkler alarm and/or water flow switch. On satisfactory observation close the alarm test valve.

SOLENOID VALVE TEST

- a. Close the inlet valve of deluge valve and open the main drain valve.
- b. Close the air supply valve and drain the air pressure through drain valve of check valve and observe low air in Pressure Switch is activated.
- c. Activate the detector (zone-1) and observe solenoid valve is activated and water flow through solenoid valve outlet and pressure drop at deluge valve top chamber.
- d. De-activate solenoid valve by build Air Pressure as per requirement in Riser and de-activate initiating zone-1 and reset then panel if required.
- e. Reset the system as per resetting procedure.

AIR SUPERVISORY LOW PRESSURE ALARM TEST

Release air pressure gradually through valve provided on check valve. When air pressure drops to 6 PSI (0.42 Bar), the supervisory low pressure alarm must be observed. Close the valve & observe that air pressure has been established to 18 PSI (1.26 Bar), the supervisory air pressure alarm must come to normal condition. If required reset the release panel.

ANNUAL OPERATION TEST

Testing valve operation without causing water apply to the deluge valve.

- a. Close the main system valve controlling water supply to the deluge valve.
- b. Open the main drain valve provided on deluge inlet side and allow water to drain. When water flow from drain valve has stopped crack open the main system valve and close the main drain valve partly allowing the water pressure at inlet of deluge valve to raise up to 1.4 Kg/Sq. Cm. (20 PSI) and no more pressure is rising.
- c. Actuate the solenoid valve from control panel as per instruction of control panel manufacturer: deluge valve must open and water flow must be noticed through drip valve and through solenoid valve. Close the main supply control valve immediately and allow water to drain from drain valve.
- d. When water flow has stopped, reset the deluge valve as per resetting procedure.

CAUTION

The steps b & c must be performed very quickly to prevent water flow to riser.

NOTE: For abnormal condition of deluge valve refer the data sheet No. HD235.

CAUTION

The system must be inspected, tested and maintained as instructed above, in addition to the requirement of NFPA or as per requirement of authority having jurisdiction. The owner is responsible for the inspection, testing and maintenance of the system and devices.

**DOUBLE INTERLOCK PREACTION SYSTEM WITH ELECTRIC/ELECTRIC RELEASE
SCHEMATIC DIAGRAM**

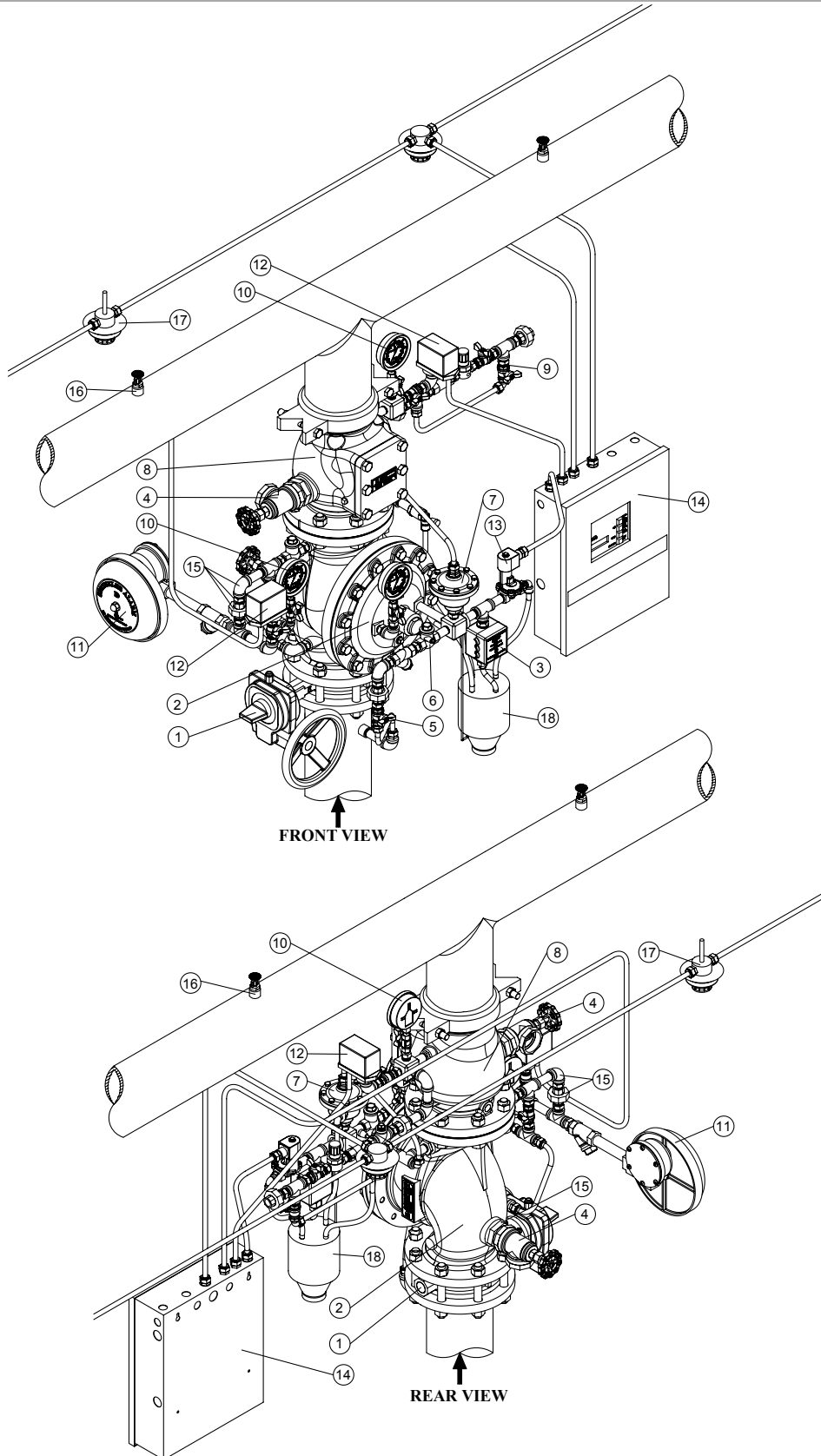

DOUBLE INTERLOCK PREACTION SYSTEM WITH ELECTRIC/ELECTRIC RELEASE PART LIST

ITEM NO	CODE NO	DESCRIPTION	PREACTION TRIM SIZE SIZE/ MAKE	QUANTITY PER PREACTION TRIM				
				200 NB	150 NB	100 NB	80 NB	50 NB
1		BFV WAFER TYPE GEAR OPRT. WITH TAMPER SWITCH *	2", HD MAKE (MODEL NO.HDMW300)	1	1	1	1	1
2	6458	DELUGE VALVE FLANGE END	2", HD MAKE (MODEL NO.DV-H3)	-	-	-	-	1
2	6455	DELUGE VALVE FLANGE END	3", HD MAKE (MODEL NO.DV-H3)	-	-	-	1	-
2	6454	DELUGE VALVE FLANGE END	4", HD MAKE (MODEL NO.DV-H3)	-	-	1	-	-
2	6453	DELUGE VALVE FLANGE END	6", HD MAKE (MODEL NO.DV-H3)	-	1	-	-	-
2	6457	DELUGE VALVE FLANGE END	8", HD MAKE (MODEL NO.DV-H3)	1	-	-	-	-
3	1951	EMERGENCY RELEASE STATION	1/2" HD MAKE (MODEL ERS-1)	1	1	1	1	1
4	9392	ANGLE VALVE	1-1/4"	-	-	-	2	2
4	9394	ANGLE VALVE	2"	2	2	2	-	-
5	9423	PRIMING VALVE	1/2"	1	1	1	1	1
6		RESTRICTED CHECK VALVE	1/2"	1	1	1	1	1
7	1825	ANTI RESET VALVE (ARV-1)	1/2"	1	1	1	1	1
8	3569	CHECK VALVE - FLANGE TO GROOVE	2", HD MAKE (MODEL NO. CH)	-	-	-	-	1
8	114345	CHECK VALVE - FLANGE TO GROOVE	3", HD MAKE (MODEL NO. CH)	-	-	-	1	-
8	114346	CHECK VALVE - FLANGE TO GROOVE	4", HD MAKE (MODEL NO. CH)	-	-	1	-	-
8	114343	CHECK VALVE - FLANGE TO GROOVE	6", HD MAKE (MODEL NO. CH)	-	1	-	-	-
8	114347	CHECK VALVE - FLANGE TO GROOVE	8", HD MAKE (MODEL NO. CH)	1	-	-	-	-
9	1674	PRESSURE MAINTENANCE DEVICE *	1/2" (PMD-1)	1	1	1	1	1
10	114071	PRESSURE GAUGE	0-300 PSI, UL LISTED	3	3	3	3	3
11	1416	SPRINKLER ALARM (GONG BELL) *	HD MAKE (TYPE-A)	1	1	1	1	1
12		PRESSURE SWITCH	POTTER MAKE, UL LISTED	2	2	2	2	2
13		SOLENOID VALVE	PARKER MAKE, UL LISTED	1	1	1	1	1
14		CROSS ZONE DV RELEASING PANEL *	POTTER MAKE, UL LISTED	1	1	1	1	1
15		TRIM FITTINGS		1	1	1	1	1
16		AUTOMATIC SPRINKLER **		-	-	-	-	-
17		HEAT DETECTOR/ SMOKE DETECTOR **		-	-	-	-	-
18		SPLASH PROOF FUNNEL		1	1	1	1	1
		* OPTIONAL SUPPLLY						
		** NOT SUPPLLIED BY HD FIRE						
		NOTES:						
		DELUGE VALVE END CONNECTION (OPTIONAL - G X G/ F X F)		F = FLANGE END				
		CHECK VALVE END CONNECTION (OPTIONAL - G X G/ F X G / F X F)		G = GROOVE END				
		BUTTERFLY VALVE END CONNECTION (OPTIONAL - G X G/ WAFER TYPE / LUG TYPE)						
		PRESSURE GAUGE (OPTIONAL - HDP-1 / HDP-2)						
		OPTIONAL TRIM SUPPLY - LOOSE / SEMI ASSEMBLED)						
		SHAPE OF FITTINGS / VALVES MAY CHANGE.						
		SYSTEM PIPING, SPRINKLER, DETECTOR NOT SUPPLIED BY HD FIRE						
		PRIMING LINE BY OTHERS						

ORDERING INFORMATION

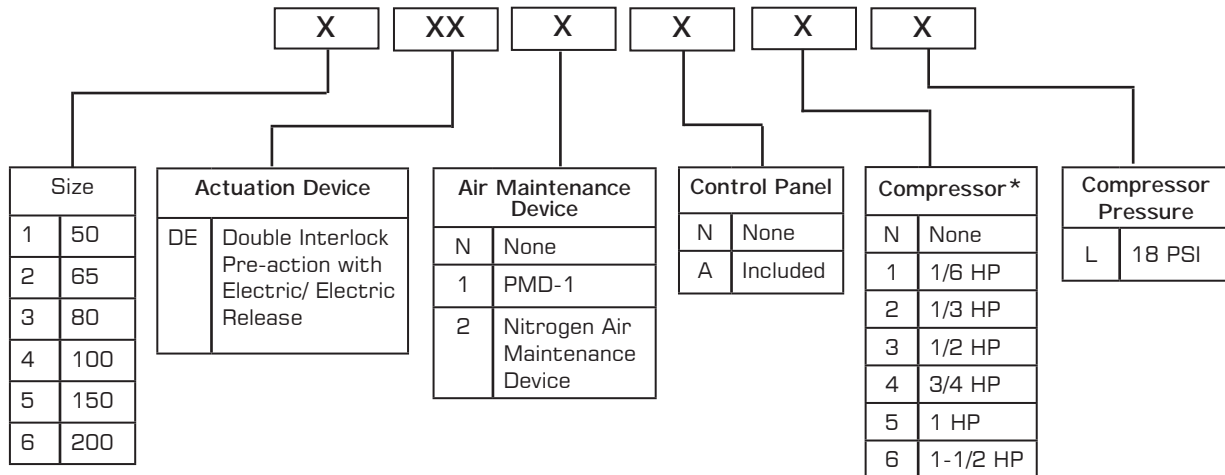

*Compressor standard supply is 50 Hz., 60 Hz is optional supply.

LIMITED WARRANTY

HD FIRE PROTECT PVT. LTD. hereby referred to as HD FIRE warrants to the original purchaser of the fire protection products manufactured by HD FIRE and to any other person to whom such equipment is transferred, that such products will be free from defect in material and workmanship under normal use and care, for two (2) years from the date of shipment by HD FIRE. Products or Components supplied or used by HD FIRE, but manufactured by others, are warranted only to the extent of the manufacturer's warranty. No warranty is given for product or components which have been subject to misuse, improper installation, corrosion, unauthorized repair, alteration or un-maintained. HD FIRE shall not be responsible for system design errors or improper installation or inaccurate or incomplete information supplied by buyer or buyer's representatives. HD FIRE will repair or replace defective material free of charge, which is returned to our factory, transportation charge prepaid, provided after our inspection the material is found to have been defective at the time of initial shipment from our works. HD FIRE shall not be liable for any incidental or consequential loss, damage or expense arising directly or indirectly from the use of the product including damages for injury to person, damages to property and penalties resulting from any products and components manufactured by HD FIRE. HD FIRE shall not be liable for any damages or labour charges or expense in making repair or adjustment to the product. HD FIRE shall not be liable for any damages or charges sustained in the adaptation or use of its engineering data & services. In no event shall HD Fire's product liability exceed an amount equal to the sale price. The foregoing warranty is exclusive and in lieu of all other warranties and representation whether expressed, implied, oral or written, including but not limited to, any implied warranties or merchantability or fitness for a particular purpose. All such other warranties and representations are hereby cancelled.

NOTICE :

The equipment presented in this bulletin is to be installed in accordance with the latest publication standards of NFPA or other similar organisations and also with the provision of government codes or ordinances wherever applicable.

The information provided by us is to the best of our knowledge and belief, and consist of general guidelines only. Site handling and installation control is not in our scope. Hence we give no guarantee for result and take no liability for damages, loss or penalties whatsoever, resulting from our suggestion, information, recommendation or damages due to our product.

Product development is a continuous programme of HD FIRE PROTECT PVT. LTD. and hence the right to modify any specification without prior notice is reserved with the company.



HD FIRE PROTECT PVT. LTD.
Protecting What Matters Most to You

D-6/2, ROAD NO. 34, WAGLE INDUSTRIAL ESTATE, THANE 400 604, INDIA.
 • TEL: + (91) 22 2158 2600 • FAX: +(91) 22 2158 2602
 • EMAIL: info@hdfire.com • WEB: www.hdfire.com